



**victron energy**  
BLUE POWER

charger  
mains on  
bulk  
absorption  
float



on  
off  
charger only

inverter  
overload  
low battery  
temperature



# EASYPLUS

ENERGY. ANYTIME. ANYWHERE.

## EasyPlus

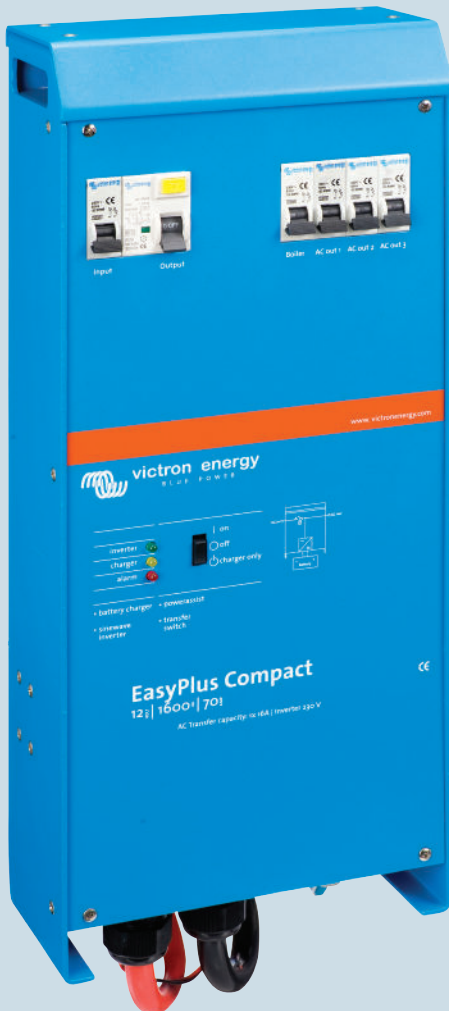

### Multi-functional power solution

The EasyPlus is a multifunctional energy system consisting of a powerful sine wave inverter, a sophisticated battery charger, a high speed AC transfer switch and AC distribution in a single light weight and compact enclosure. The system has been designed for those who want to enjoy the comfort and freedom of a complete energy system without spending time on the installation of separate components and difficult technical procedures

### Optimum comfort and safety

The EasyPlus guarantees uninterrupted power supply, whenever and wherever you are. Where shore or generator power is limited, the unique PowerAssist® technology makes it possible to boost the total capacity by adding extra energy from the batteries. Optimum safety is guaranteed with the integrated RCD (Residual Current Device) protecting against earth leakage.

### 5 step installation: quick and easy

The EasyPlus gets its name from the simplicity of installation and use. The system can be installed within five simple steps making significant savings in time as well as space. The EasyPlus provides plugs and sockets for all AC connections and is supplied with the battery cables already fitted so you can save hours in installation time.

**Step 1.** Select a suitable place for the EasyPlus (as close as possible to the batteries) and install the wall mounting bracket. Attach the EasyPlus to the bracket and secure it with the screws provided.

**Step 2.** Connect the shore/generator input power and the outgoing circuits (including dedicated water heater feed) to the EasyPlus.

**Step 3.** Connect the control panel (optional) with the UTP patch lead.

**Step 4.** Connect the battery cables and temperature sensor to the batteries (also supplied as standard).

**Step 5.** Switch on the RCD, the AC distribution and the inverter/charger and the system is ready to use.

## How does it work?

The EasyPlus is connected to the batteries and to the shore power or generator. The maximum available generator or shore current is set using the dial on the control panel. The power consumers are divided into two groups. The first group consists of the 'regular', low or short term power users such as sockets or kitchen equipment. This group can be fed from both shore/generator and battery power via the inverter. The second group is the 'heavy user' circuit. This can be a water heater or the air-conditioning. In order to protect the batteries from excessive discharge, this group is shore/generator-only and cannot be supplied when the inverter is functioning. Unique PowerAssist® technology protects the shore or generator from being overloaded by adding extra inverter power when needed.

## Technical information

12 Volt 1600 VA sine wave inverter (3000 Watt peak power).

70 A charger incl. 4 A trickle charge for start battery.

Unique PowerAssist® technology protects the shore or generator from being overloaded by adding extra inverter power when needed.

4 Stage adaptive charge technology for quick and accurate battery charging.

The AC distribution consists of a RCD (30mA/16A) and four AC outputs protected by two 10 A and two 16 A circuit breakers.

One 16 A output is controlled by the AC input: it will switch on only when AC is available.

RCD (30 mA/16 A) on AC output.

No-break system: uninterrupted switching between shore/generator and inverter.

Battery cables included.

### Dimensions

Height : 510 mm

Width : 214 mm

Depth : 110 mm

Weight : 11,7 Kg



## Typical installation and wiring diagram

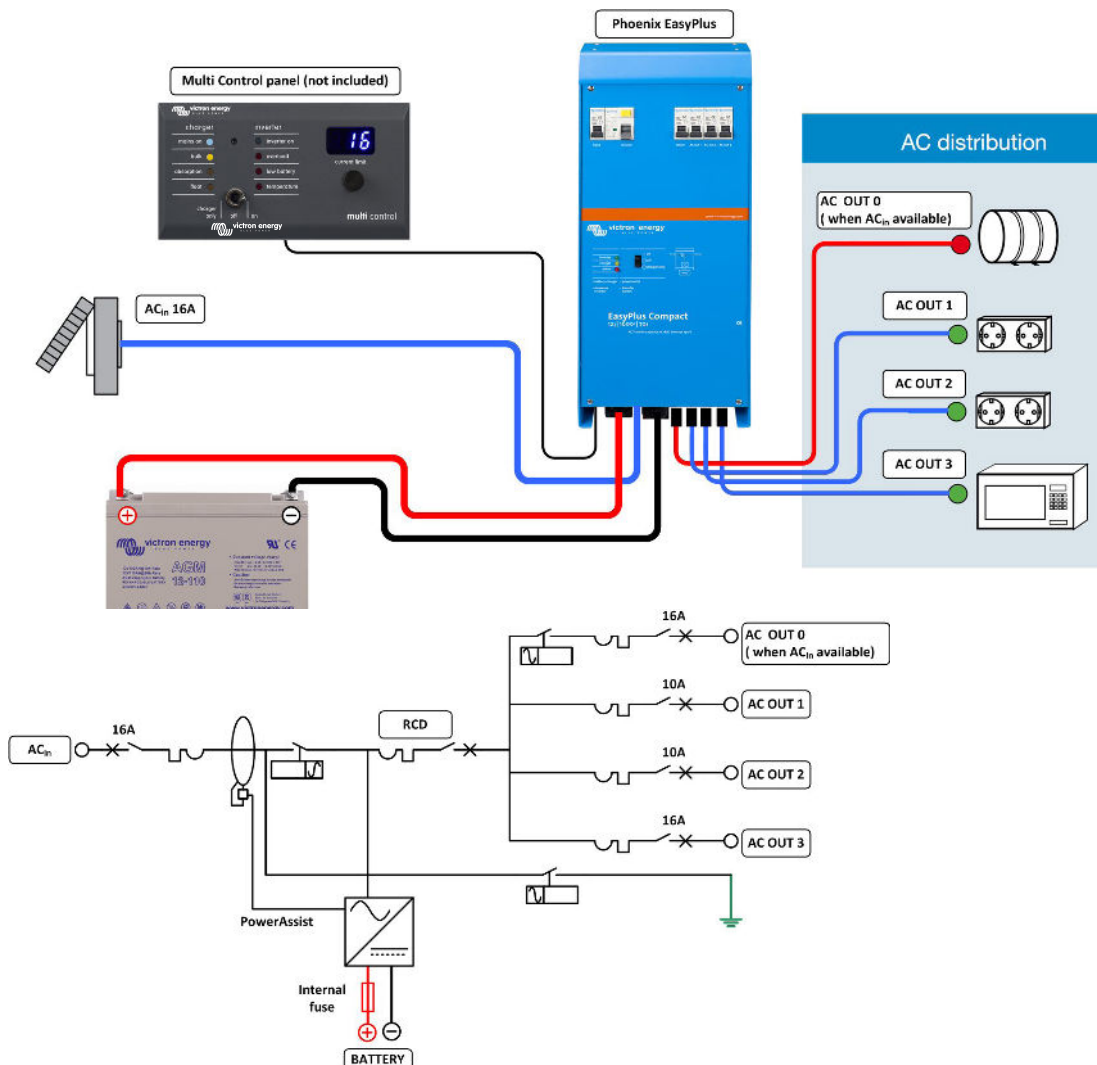



Victron Energy B.V. / De Paal 35  
1351 JG Almere / The Netherlands  
Phone: +31 (0)36 535 97 00  
Fax: +31 (0)36 535 97 40  
e-mail: [sales@victronenergy.com](mailto:sales@victronenergy.com)  
[www.victronenergy.com](http://www.victronenergy.com)

SAL064100020  
REV 04  
2016-01