

Mounting instructions

tile roof - top-fix

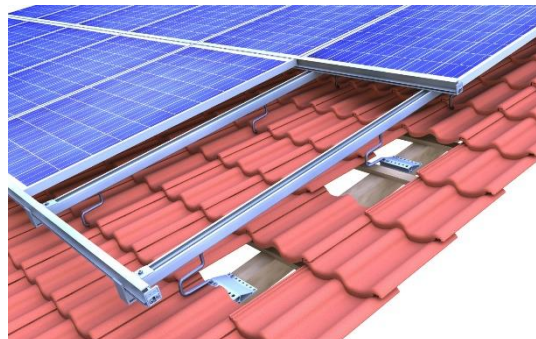
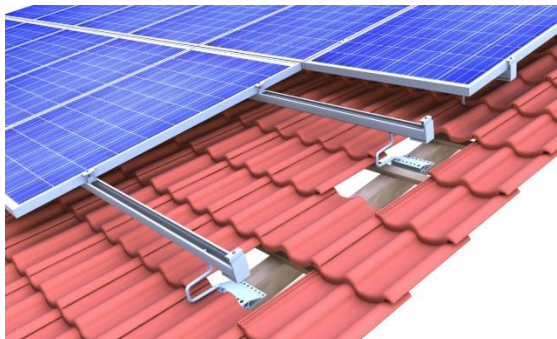
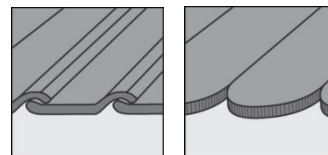

TABLE OF CONTENTS

1	Notes	1
2	Maintenance of the mounting system	4
3	novotegra for tile roof	4
4	System components, tools and equipment	5
4.1	What is required for mounting	5
4.2	Mounting system components – mounting versions	6
4.3	Mounting system components – optional	7
5	Installing the mounting system	8
5.1	Roof hook mounting	8
5.2	Rail mounting	9
5.3	Module mounting	10
5.4	Mounting versions	11
6	Warranty / product liability (exclusion)	18

1 Notes

The following instructions are generally valid for our mounting system novotegra and are to be applied or interpreted accordingly regardless of the respective roof and mounting system type.

Safety information

Mounting tasks may only be carried out by qualified and competent persons. During the work protective clothing in accordance with the relevant national regulations and guidelines must be worn.

Mounting must be carried out by at least two persons to ensure help in case of an accident.

All relevant national and locally applicable health and safety regulations, accident prevention regulations, standards, construction standards and environmental protection regulations as well as all regulations of the employers' liability insurance associations must be complied with.

The national regulations for working at height / on the roof must be complied with.

Electrical work must be carried out in compliance with the national and locally applicable standards and guidelines and the safety rules for electrical work.

Earthing / equipotential bonding of the mounting system must be carried out in accordance with the national and locally applicable standards and guidelines.

Categorisation into hazard classes

To alert the user of potential danger situations the hazard classes analogous to ANSI Z 535 are used. The hazard class describes the risk if the safety information is not observed.

Warning symbol with signal word

Hazard class analogous to ANSI Z 535



DANGER! describes an immediate danger. If it is not avoided, death or serious injury will result.



WARNING! describes a potential danger. If it is not avoided, death or serious injury might result.



CAUTION! describes a potential danger. If it is not avoided, light or minor injury might result.



NOTE! describes a potentially harmful situation. If it is not avoided, the plant or objects in its vicinity might be damaged.

General information

After receipt the goods must be inspected for completeness using the accompanying delivery note.

novotegra GmbH does not accept the costs, nor can we guarantee subsequent express deliveries if missing material is only noticed during mounting.

Since our mounting systems are subject to continuous development, mounting processes or components may change. Therefore, please check the current status of the mounting instructions on our website prior to mounting. We are also happy to send you current versions upon request.

The mounting system is suitable for the attachment of PV modules with standard market dimensions. Please find more detailed information about this in chapter 3.

The usability of the mounting system for the respective project must be checked for each individual case on the basis of the roof cover / roof construction / facade present.

The roof cover / roof construction / facade must meet the requirements of the mounting system with regard to load bearing capacity, support structure and condition.

Requirements for the material of the roof construction / roof cover / facade:

Wooden components (rafters/purlins): min. strength class C24, no fungus infection or rot

Tensile strength R_m , min for trapezoidal metal: steel 360 N/mm²; aluminium 195 N/mm²

Wall construction material: concrete, brick or sand-lime brick in solid or hollow block design.

The load bearing capacity of the roof / roof construction (rafters, purlins, trapezoidal metal, concrete floors, number of adhesive points, folded seams, etc.) or the facade (wall construction materials) must be checked by the user or a check be commissioned.

Physical building aspects concerning insulation penetrations (e.g. condensation) must be taken into account by the user.

Notes on mounting

The components of the novotegra mounting system are intended exclusively for the attachment of PV modules. Dependent on the roof type of the building the designated mounting system components must be used.

A condition for the intended use of the novotegra mounting system is the mandatory compliance with the specifications in these instructions regarding safety information and mounting.

In case of unintended use and non-compliance with the safety information and mounting instructions and non-utilisation of the corresponding mounting components or use of third party components not belonging to the mounting system any warranty and liability claims against the manufacturer are voided. The user is liable for damage and resulting consequential damage to other components, such as PV modules, or the building as well as personal injury.

The user must read the mounting instructions prior to mounting. Unresolved issues must be clarified with the manufacturer prior to mounting. The mounting sequence in these instructions must be adhered to.

It must be ensured that a copy of the mounting instructions is accessible in the immediate vicinity of the work on site.

The mounting specifications (module load, attachment, clamping areas etc.) of the module manufacturer must be observed and complied with.

Prior to mounting the mounting system must be statically calculated with the loads to be assumed for the building project in accordance with the national standards. Information relevant to mounting (e.g. roof hook distance, lengths of bolts, overhang and protrusions or distance of base trough and required ballast) must be determined by the static calculation using the design software www.solar-planit.

The permissible roof inclination for using the mounting system according to these installation instructions is 0 to 60 degrees for roof-parallel installation on a pitched roof and 0 to 5 degrees for elevated installation on a flat roof. Facade systems must be mounted parallel to the facade.

For roof-parallel installation with the clamping system, two module support rails per module must be mounted symmetrically under the modules for equal load transfer into the substructure. Alternatively, the roof-parallel installation can also be installed with insertion rails.

The specified tightening torques must be adhered to and checked randomly on site.

Notes on static calculations

The mounting system must generally be statically calculated for each individual project using the design software Solar-Planit. Excluding façade systems, the calculation for this will be carried out by the company novotegra GmbH.

The static calculation only determines the load bearing capacity of the novotegra mounting system and also takes account of the attachment to the building (rafters, purlins, trapezoidal metal, facade etc.). The load transfer within the building is not considered (customer static calculations).

The load bearing capacity of the mounting system components is determined on basis of the planned module layout and the underlying building information (project data recording). Deviations from the planning on site may lead to different results.

The load assumptions (load and roof division) are country-specific in accordance with the specifications of the Eurocode load standards. The determination of the loads to be assumed for Switzerland is in accordance with SIA 261.

At pitched roof, the modules may not be fitted above the gable end, ridge and eaves or the facade (increased wind load). At the ridge the modules may be fitted up to max. a theoretical horizontal line with the ridge tile and perfectly flush with the gable end. In the eaves area the modules may reach to max. the end of the roof cover due to loads.

In case of an exposed building position (with wind load e.g. at the edge of a slope) or snow accumulation (e.g. dormer or catchment grill or roof structures like domelights etc) the specifications of the Eurocode load standards or SIA 261 (Switzerland) must be taken into account by the user within his own responsibility. The design software does not consider these cases.

The static calculation of the mounting system is based on the symmetrical placement of the modules on the mounting rails at the longitudinal side of the modules (roof-parallel clamping systems) or on the support components (elevation) for equal load transfer into the substructure. For the insertion system a cross rail arrangement is expected for equal load transfer.

The results calculated with the design software, such as distances of the fasteners (e.g. roof hooks, stock screws, saddle clamps etc.), rail lengths and number of fasteners (e.g. direct attachment on the trapezoidal metal), overhang (e.g. rail and roof hook protrusions) or distances between the base troughs and number of fixing materials (e.g. rail joint) and the other calculation notes must be considered and complied with.

novotegra has been tested and certified by TÜV Rheinland:



2 Maintenance of the mounting system

The mounting system must be checked for stability and operation at regular intervals during the system maintenance.

In addition to the visual inspection of the components, we recommend a random check of the connections and the safe and correct position of the ballast on the base rails and ballast troughs.

Removal is possible in reverse order in the work steps mentioned below.

The maintenance work must be carried out by a specialist company with proven experience in electrical systems and work on mounting systems.

3 novotegra for tile roof

These mounting instructions the design of the substructure on roofs with clay tiles, concrete roof tiles or plain tile covering. The maximum permissible module width is 1.34 m for the respective mounting system to be used.



The mounting steps can be applied correspondingly to the installation on roofs with slate covering. However, in the area where the roof hooks exit the roof cover hoods or lead flashing is required to prevent water ingress. Please contact us for support in advance of such mounting tasks.

4 System components, tools and equipment

4.1 What is required for mounting

Figure	Tool	Component*	Product group
		Roof hook set Material: stainless steel and Aluminium Tool: Special long nut socket 18mm	Roof attachment
		Roof hook mounting screw Material: Galvanised steel or stainless steel Tool: Torx drive TX 25/40 mm with 70 mm length	Roof attachment
		C-rail Material: Aluminium	Profile rails
		Rail connector set C Material: Aluminium and stainless steel Tool: Special long nut socket 18mm	Rail connectors and expansion joints
		Rail connector set C47 S	Rail connectors and expansion joints
Clamping system			
		Middle clamp Set C Material: Aluminium, Aluminium cast and stainless steel Tool: 8 AF hexagon drive	Module attachment
		End clamp Set C Material: Aluminium, Aluminium cast and stainless steel Tool: 8 AF hexagon drive	Module attachment
		Module slip guard set Material: stainless steel	Module protection and rail top cover

* The components vary dependent on the roof requirements, the static calculation or the component selection and may differ from the figures above.

Figure	Equipment	Use for tools	Application
	Cordless screwdriver	Torx TX bit 40, 30 or 25 Socket AF 8	Component attachments, clamp mounting
	Torque spanner up to min. 50 Nm	Special socket AF 18 deep	Rail assembly
	Torque spanner up to min. 10 Nm	Socket AF 8	Clamp assembly



Mitre saw

Rail section

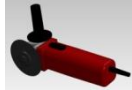

Angle grinder

Tile adaptation



Bit extension





Torx TX bit 40, 30 or 25

Roof hook mounting

4.2 Mounting system components – mounting versions

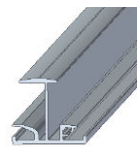
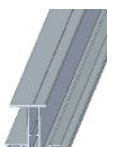
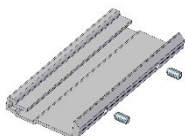
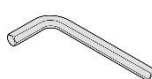
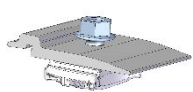
Figure	Tool	Component**	Product group
 <p>M14</p>		<p>Cross rail connector set C Material: Aluminium cast and stainless steel Tool: Special long nut socket 18mm</p>	<p>Rail connectors and expansion joint</p>
		<p>Expansion joint Material: Aluminium and stainless steel Tool: Special long nut socket 18mm</p>	<p>Rail connectors and expansion joint</p>
		<p>Slip guard for landscape mounting Material: Aluminium and stainless steel Tool: Special long nut socket 18mm</p>	<p>Module protection and rail top cover</p>

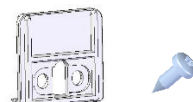



Insertion system

		<p>Insertion rail Material: Aluminium</p>	<p>Profile rails</p>
		<p>Insertion rail plus Material: Aluminium</p>	<p>Profile rails</p>
		<p>Rail Connector set IR Material: Aluminium and stainless steel Tool: Hexagon socket AF 3</p>	<p>Rail connectors and expansion joint</p>
		<p>Cross rail connector set C IR Material: Aluminium and stainless steel Tool: Socket AF 13</p>	<p>Rail connectors and expansion joint</p>
		<p>Support rail IR Material: Aluminium</p>	<p>Profile rails</p>
		<p>Edge stop set IR Material: Aluminium and stainless steel</p>	<p>Module protection and rail top cover</p>

		Tool: Torx drive TX30 Edge stop set IR Plus Material: Aluminium and stainless steel	Module protection and rail top cover
		Tool: Torx drive TX30 Mounting set snowguard IR Material: Aluminium and stainless steel	Accessories and optional components
		Tool: Socket AF 8 Snowguard IR 20x5 Alu round pipe Material: Aluminium	Profile rails
		EPDM-T protection IR Material: EPDM	Module protection and rail top cover

** Required components dependent on the substructure (e.g. cross rail arrangement), system design (e.g. with expansion joint) or module layout (e.g. Mounting modules in landscape).

4.3 Mounting system components – optional

Figure	Tool	Component***	Product group
		End cap C-rail Material: Aluminium and stainless steel Tool: Special long nut socket 18mm	Module protection and rail top cover
		Top cover C-rail 2,000 mm Material: Aluminium	Module protection and rail top cover
		End cap C-rail black	Module protection and rail top cover
		Mounting-Set C-rail with plate	Accessories and optional components
		Grounding connector set AF 18 Material: stainless steel Tool: Special long nut socket 18mm	Accessories and optional components
		Cable-tie clip for profile flange	Cable fixing
		Cable clip d = 10 mm	Cable fixing
		Contact latch module clamp	Accessories and optional components

*** Optionally available mounting system components e.g. for the visual enhancement of the system, cable laying or the earthing of the mounting system.

5 Installing the mounting system

Prior to mounting, the module field on the roof must be measured and the position of the fasteners (e.g. roof hooks, stock screws, saddle clamps etc.) defined taking into account the static calculation.

The individual mounting steps for mounting modules in portrait are explained below. Reference is made to the mounting versions (MV) for the various design options (e.g. cross rail mounting or insertion system). This is followed by the corresponding work steps.

5.1 Roof hook mounting

Expose rafters

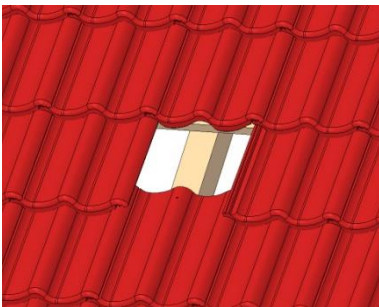

Expose the rafters by removing the tiles.

⚠ WARNING

To execute the work a scaffold must have been installed in accordance with the relevant specifications.

Position roof hook

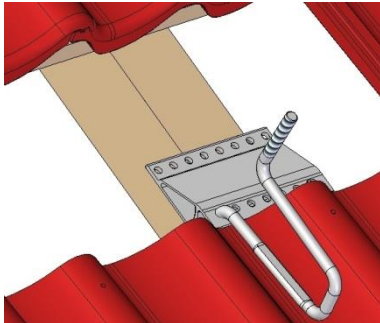

Version Flex roof hook

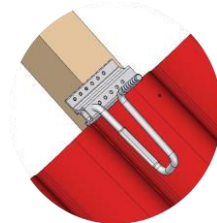

Insert roof hook with the bracket positioned in the trough of the roof tile. The position of the roof hook on the rafter must be defined taking into account the static specifications (MV 1.4). Mark the top tile and, if necessary, the bottom tile at the roof hook exit point. For plain tile covering proceed according to MV 1.2 + 1.3.

Tile cut-out

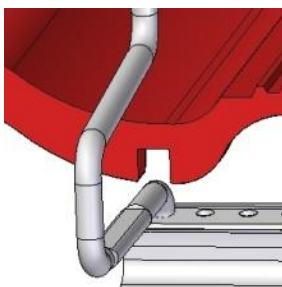

Interlocking tiles / concrete roof tile:

At the exit area of the roof hooks carefully make a cut-out with the angle grinder.

Plain tile:

Cut out laterally continuous or latched for bracket thickness.

⚠ WARNING

Observe accident prevention regulations, prevent material damage!

Maintain gap

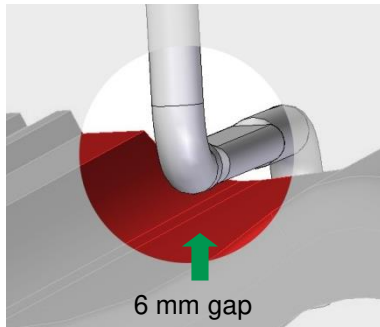

Height adjustment of the roof hooks through the thread in the base profile. The distance between the bottom tile and bracket must be 6 mm after attachment.

NOTICE

If the gap is not observed, the bottom tile might be damaged under load.

Attach roof hook

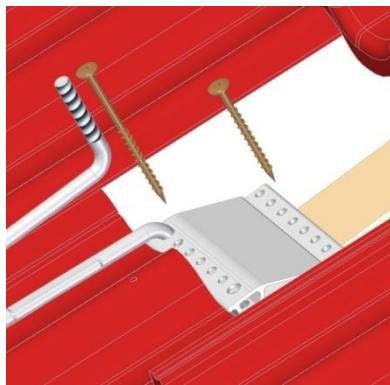

Version Flex roof hook

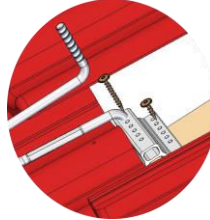

Attach the roof hooks to the rafter with wood screws (MV 1.4). The screw length depends on the roof design and is determined by the calculation software. If the counter battens were not taken into account in the design software or mounting is on a rafter insulation, the base profile of the roof hook must be padded on both sides of the counter batten for at least the width of the rafter.

NOTICE

The wood screws used in the system are approved by building authorities. If your own or non-equivalent screws are used, the system static becomes void.

5.2 Rail mounting

Mounting the rail

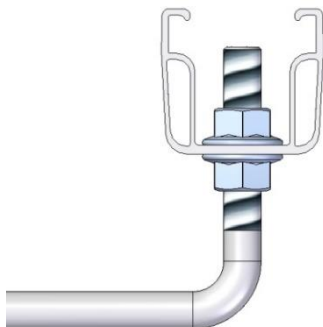

Place the C-rail onto the lower self-locking nut, align the rail and tighten it with the top self-locking nut. The roof hook can also be connected to the rail connector in the joint area. For mounting in the cross rail arrangement (insertion/clamping system) the top rail is attached using the cross rail connector or Cross rail connector set C IR M8 (MV 2).

NOTICE

Self-locking nut tightening torque 50 Nm.

Connect the rail



Join the rail ends flush, apply the rail connector centred and connect it to the rail using the mounting screws included in the set. The connector and number of screws depend on the rail (MV 3). Maximum uninterrupted rail length 13 m, then install expansion joint or disconnect the rail (MV 3.3).

NOTICE

Self-locking nut tightening torque 50 Nm.

WARNING

The accident prevention regulations must be complied with when cutting to size.

5.3 Module mounting

Module protection

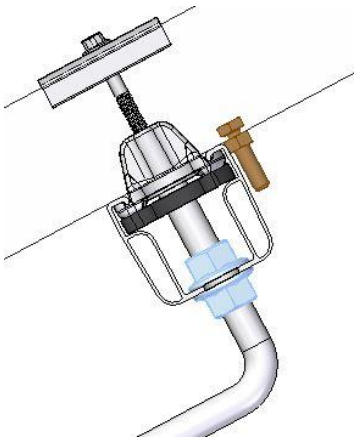

Prior to mounting the modules the slip guards must be fitted to the frame holes above the bottom rail position (MV 4).

Module clamping

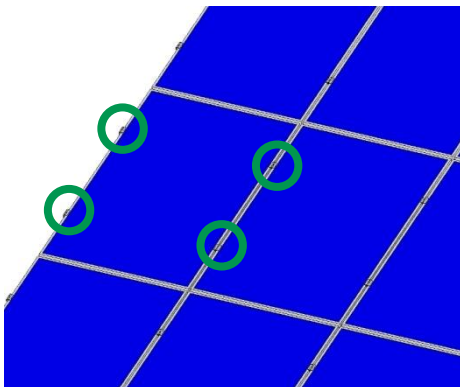

The modules must then be attached to the rails using end clamps and middle clamps.

For the insertion system module mounting see MV 5.

Mounting the middle and end clamps

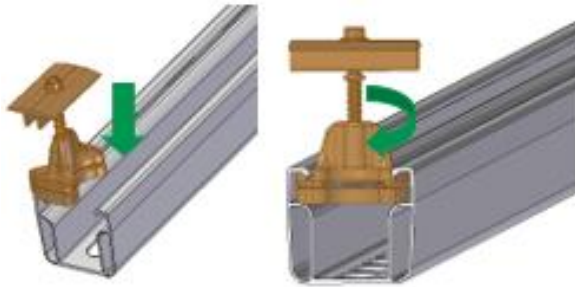

Insert the middle clamps or end clamps at the clamping position from above into the rail chamber. Then turn the rail nut in the rail and push the module clamps towards the module frame.

Space requirement for middle and end clamps

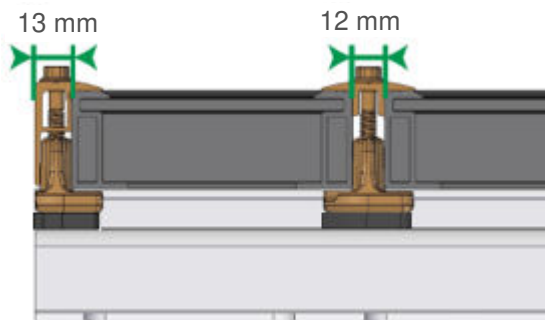

End clamp mounting flush with the rail end possible.

Push the modules all the way towards the rail nut of the middle clamps.

NOTICE

Middle clamp tightening torque 10 Nm,
End clamp tightening torque 8 Nm.

5.4 Mounting versions

Explanation of the mounting versions dependent on the roof design or design version (e.g. insertion system or cross rail arrangement)

MV 1 Roof hook

MV 1.1 Versions

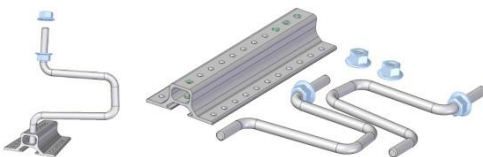

- Flex roof hook set / double flex roof hook set:
- for roof tiles / concrete roof tiles and plain tile coverings
 - Base profile height 30 or 40 mm
 - M10 bracket



- Roof hook set ZD / double roof hook set ZD:
- for roof tiles and concrete roof tile
 - Base profile height 30 or 40 mm
 - M12 bracket

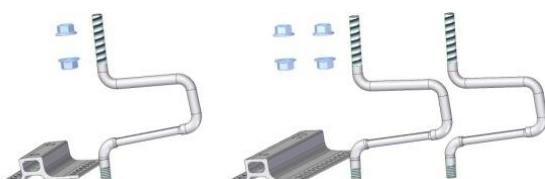

- Roof hook set BS / double roof hook set BS:
- for plain tile coverings
 - Base profile height 30 mm
 - M12 bracket

MV 1.2 Positioning roof hooks with plain tiles

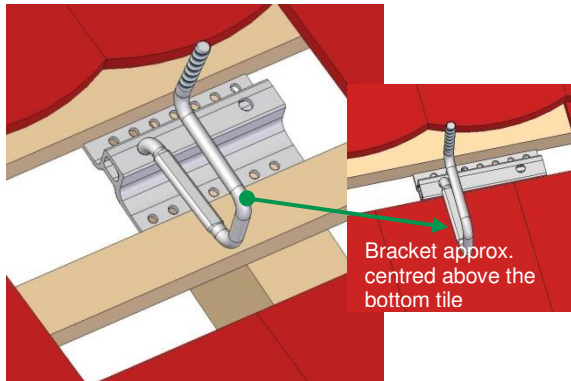

Install the roof hook with the long side of the base profile facing down. Position the bracket whilst maintaining the lateral overhang (MV 1.4) approx. centred above the tile below.

MV 1.3 Covering roof hooks with plain tiles



1. Cover plain tile up to the roof hook.
2. Insert cut-out plain tile.
3. Install plain tiles above.

MV 1.4 Mounting the roof hook

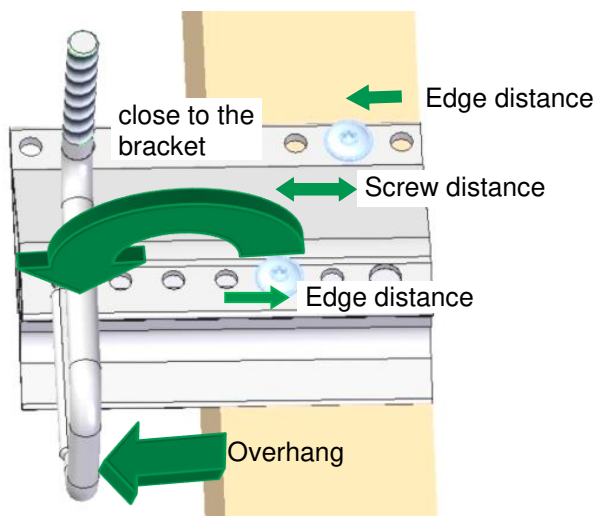

The permitted overhang of the roof hook beyond the rafter can be found in the project static calculations. The wood screws must be screwed in without predrilling with the largest possible screw distance to each other whilst maintaining the edge distances to the rafter. The wood screw in the bracket axis must be screwed in as close as possible to the bracket. For the roof hook set BS this applies to the wood screw of the top screw axis. For the double roof hook set the same specifications apply correspondingly.

Edge distances:
 Screw $d = 6 \text{ mm}$ $\rightarrow R = 18 \text{ mm}$
 Screw $d = 8 \text{ mm}$ $\rightarrow R = 24 \text{ mm}$

NOTICE

For rafter insulation mounting the roof hook must be installed with wood screws $d = 8 \text{ mm}$ only.

MV 2 Mounting Cross rail connector

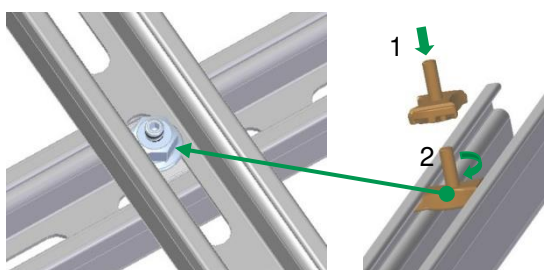

Cross rail mounting:
 Insert the Cross rail connector sets C M14 from above into the rail groove (1) and rotate by 90° (2).

NOTICE

Cross rail connector set C M14 tightening torque 40 Nm .

MV 3 Rail connectors

MV 3.1 Mounting the C-rail rail connectors

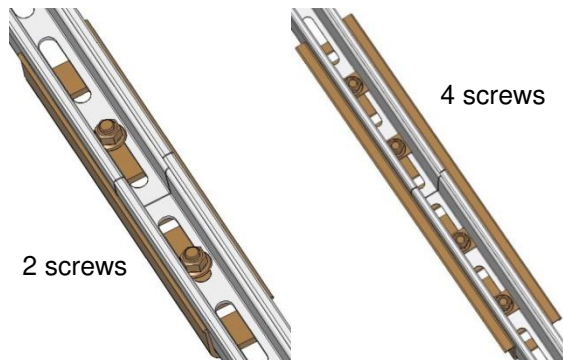

Rail connectors:

C-rail 47 (left):

Connect the adjacent rail ends with one screw and self-locking nut each.

C-rail 71 and C-rail 95 (right):

Connect the adjacent rail ends with two screws, washers and self-locking nuts each.

NOTICE

Self-locking nut tightening torque 50 Nm.

MV 3.2 Mounting rail connector set C47 S

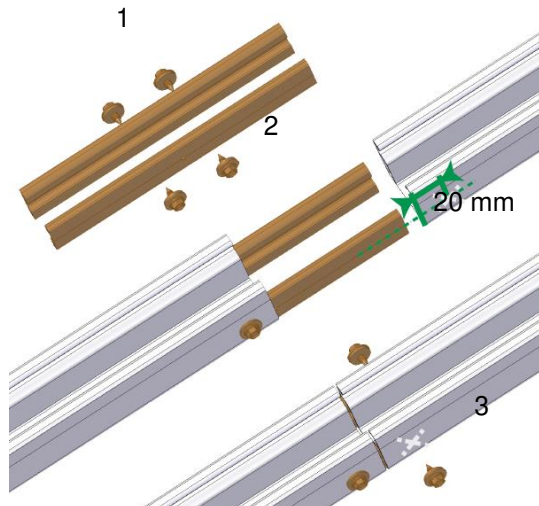

Push the rail connector set (1) half way into one of the rails to be connected (2) and secure it there with a drilling screw each on both sides approx. 20 mm from the rail end. Next push the other rail completely onto the rail connector set until both rail ends make contact (3) and screw it tight as described above. Maximum uninterrupted rail length 13 m, then install expansion joint.

WARNING

The accident prevention regulations must be complied with during cutting to size.

MV 3.3 Mounting expansion joints for C-rails

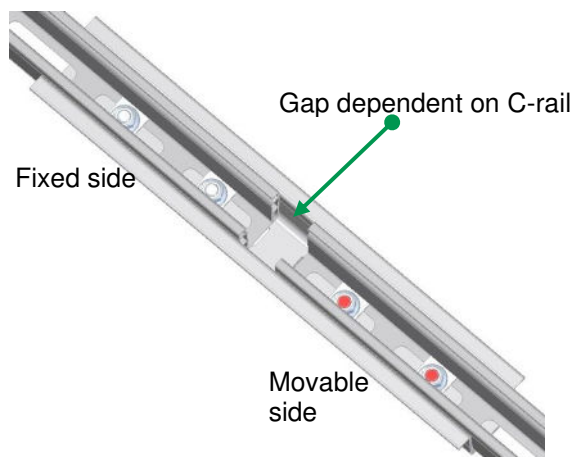

Place rail ends onto the gap, apply the rail connector and connect it to the rail at the fixed and movable sides using the mounting screws. Tighten the screws firmly on the fixed side. The screws on the movable side are coated in red and must be released again after tightening (approx. 1/2 turn). Maximum rail length with expansion joint 40 m, then plan proper rail disconnection.

NOTICE

Self-locking nut tightening torque fixed side 50 Nm. Distance of adjacent rail ends.

C-rail 47: 20 mm

C-rail 71 and 95: 40-50 mm

MV 4 Module slip guard

MV 4.1 Modules with box frame

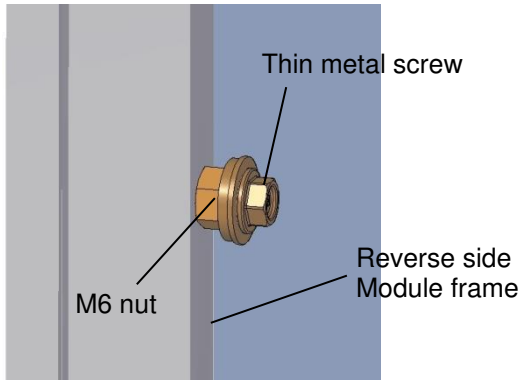

Push the nut over the screw and screw the thin metal screw into the module frame without predrilling.

NOTICE

The thin metal screw must not be overtightened.

MV 4.2 Module mounting in landscape

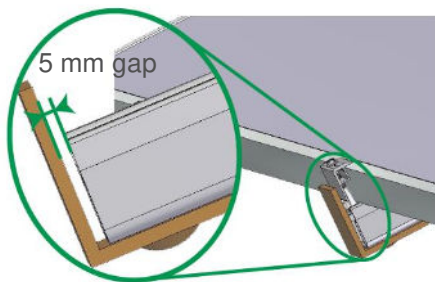

Screw the slip guard to the rail end with approx. 5 mm gap using mounting screw and self-locking nut.

NOTICE

Self-locking nut tightening torque 50 Nm.

MV 5 Insertion system

MV 5.1 Cross rail connector C IR

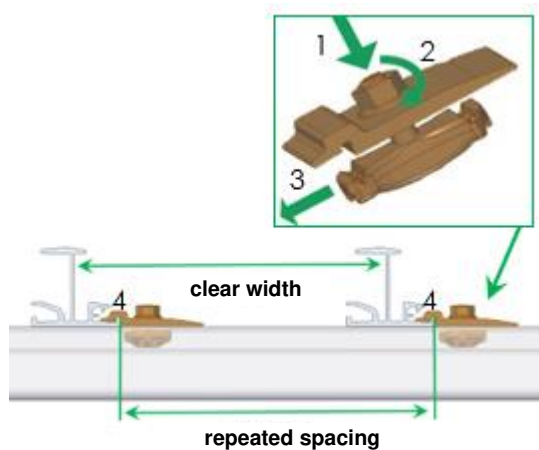

Insert the Cross rail connector set C IR M8 into the rail groove (1) from the top, rotate the nut by 90° (2) and push the component against the insertion rail (3) until the Cross rail connector set C IR M8 engages with the mounting flange (4).

NOTICE

Cross rail connector set C IR M8 tightening torque 25 Nm.

Repeated spacing = module length L + 12 mm

Clear rail width = module length L + 10 mm

For mounting modules in landscape the module width must be used instead of the module length.

MV 5.2 Position of the cross rail connector IR

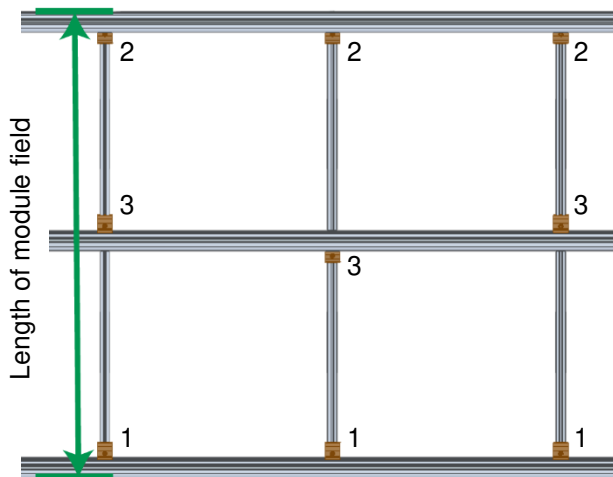

For the top and bottom insertion rail of the module field the Cross rail connector set C IR M8 is fitted on the inside in each case (1, 2), at the centre insertion rails the Cross rail connector set C IR M8 must be fitted alternating at the top and the bottom at the mounting flange (3).

NOTICE

Module field length =
Repeated spacing x number of module fields
+ width of insertion rail

MV 5.3 Mounting the rail connector IR

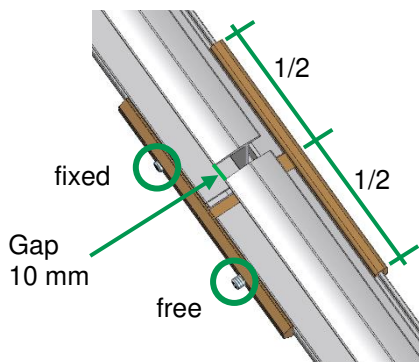

Centre the rail connector over the fitted rail and tighten the first threaded pin. Insert the rail to be connected into the connector, gap between the rails 10 mm, tighten the second threaded pin without play.

NOTICE

Do not fit connectors at the cantilever and above the drop rail.
Threaded pin without play for longitudinal expansion.

MV 5.4 Module mounting: insertion system

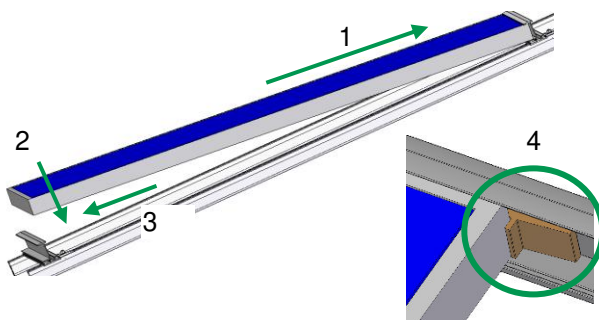

Place the module onto the top insertion rail and push it up (1). Then lower the module onto the bottom insertion rail (2) and push it down against the insertion rail (3). Mount the next modules following the same principle, the gap between the modules must be min. 3 mm.

NOTICE

Install the EPDM-T protection IR between the modules (4) with a module inclination <math>< 10^\circ</math> or as theft protection.

MV 5.5 Edge stop mounting

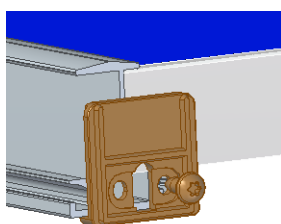

Fit an edge stop at the end of a module row at each insertion rail with a metal screw in the screw channel.

NOTICE

The opening of the edge stop must expose the drainage channel of the insertion rail.

MV 6 High snow loads

MV 6.1 Assembly insertion rail Plus

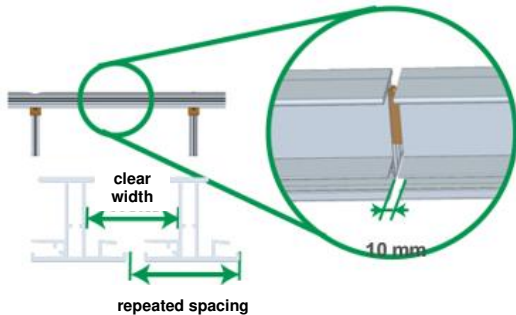

Fasten insertion rail Plus on C-rails with cross rail connector set C ES like insertion rail. Insert connector insertion rail Plus up to the stop and push the second rail over the rail connector with a distance of 10 mm.

NOTICE

Repeated spacing of rails = module length L + 22 mm

Clear width of rails = module length L + 10 mm

MV 6.2 Mounting the support rail IR

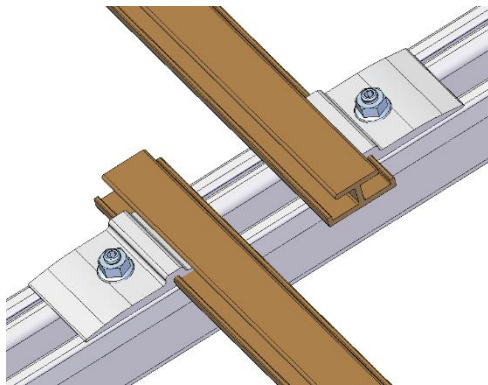

Dependent on the module load it might be necessary to install a support rail centred under the module. Attachment is with the Cross rail connector set C IR M8. The support rails must be fitted parallel to the insertion rails and must be offset on the C-rail in the overlap area.

NOTICE

A 6.0 m long support rail must be attached with min. 3 cross rail connector sets C IR M8.

MV 6.3 Snowguard –lay out the Alu round pipes

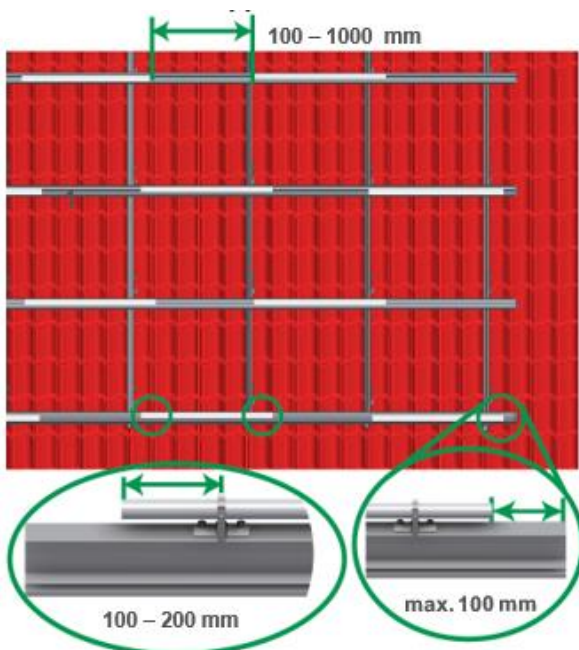

Distance between Aluminium round pipes at the end of the insertion rail in the corner area of the system max. 100 mm.

Distance between round pipes min. 100 mm and max. 1000 mm.

For each 800 mm round pipe at least two brackets must be mounted at a distance of 100 – 200 mm from the end of the pipe.

The same mounting instructions apply to 6.0 m round pipes. Mounting distance of the brackets here is 500 – 600 mm each.

NOTICE

Arrange snow stop ES 20 x 5 aluminium round pipes per row of rails in a staggered arrangement, observing the minimum and maximum distances.

MV 6.4 Fixing mounting set snowguard IR and edge stop set IR Plus

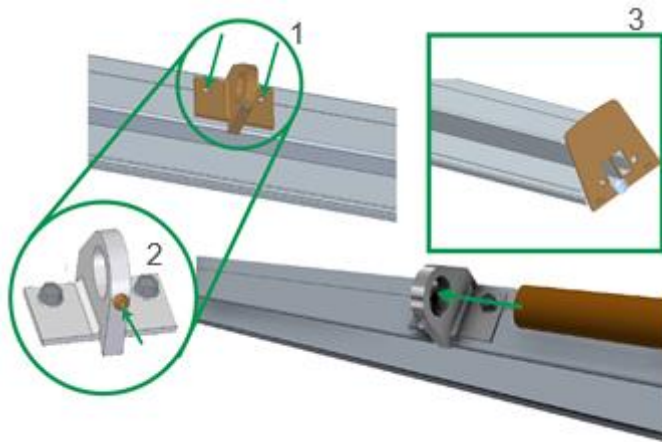

The mounting brackets snowguard IR have to be fixed on the insertion rail Plus with two drilling screws (1). Position the round pipes centrally and fix them with the grub screw (2).

Mount the edge stop at the end of a module row on each insertion rail with a self-tapping screw in the screw channel (3).

NOTICE

If round pipes pass over a rail joint, tighten only one grub screw.
The openings of the edge stop must be release the drainage channels of the insertion rail.

MV 7 Grounding

MV 7.1 Assembly of grounding connectors

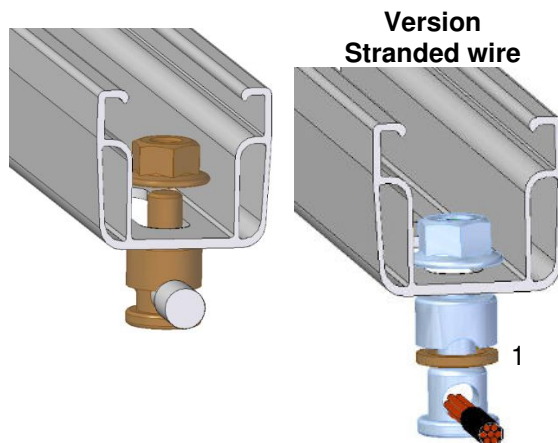

Earthing wire (\varnothing according to national specifications):
Remove grounding connector, remove clamping disk (1). Push component through C-rail slot from below. Push earthing wire through the opening (suitable for \varnothing 6-10 mm) and attach the component to the rail floor with the self-locking nut.

Earthing cable (\varnothing according to national specifications):
Strip earthing cable (e.g. stranded wire) and push it through the opening. Leave the clamping disk in place (1). Clamp to the rail floor with the self-locking nut.

NOTICE

Earthing wire tightening torque 20 Nm or earthing cable 10 Nm.

⚠ WARNING

The applicable standards and guidelines, e.g. lightning protection standard, must be observed.

MV 7.2 Assembly of contact latch

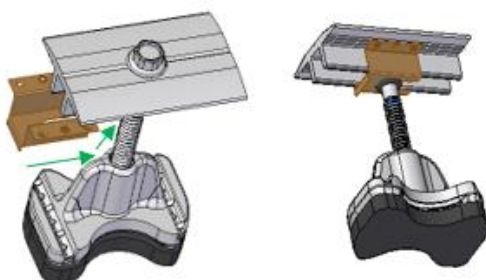

Push the contact latch on the sliding plate over the vertical webs of the middle clamp up to the screw.

NOTICE

Mounting of the middle clamp with the contact latch attached is carried out as described previously in chapter 5.3.

6 Warranty / product liability (exclusion)

In addition to the above-mentioned regulations and safety notices the applicable regulations and rules of technology must be observed by the installing specialist company.

The installer is responsible for the dimensioning of the mounting system.

The installer is responsible for the connection of the interfaces between the mounting system and the building. This also includes the tightness of the building envelope.

For flat roofs the roof insulation must be evaluated by the installer on site within his own responsibility regarding the material of the sealing layer, resistance, ageing, compatibility with other materials, overall condition of the roof insulation, need for a separating layer between the roof insulation and the mounting system. The required and necessary measures or precautions for the protection of the roof insulation for the mounting of the substructure of a PV system must be initiated by the installer with the aid of a specialist tradesman where necessary. novotegra GmbH does not accept liability for faulty or inadequate measures and precautions for the protection of the roof insulation!

The installer must review the friction coefficient used in the calculation for the verification of the slip safety of PV systems on flat roofs on site. Friction coefficients determined on site can be taken into account by entering them in the Solar-Planit planning tool. novotegra GmbH does not guarantee the correctness of the assumed values and is not liable for damage due to the use of incorrect values.

The specifications of the module, cable and inverter manufacturers must be observed. If these contradict the mounting instructions, always consult the novotegra GmbH sales team before mounting the novotegra mounting system or – in the case of components not supplied by novotegra GmbH – the manufacturer concerned.

During the preparation of the offers for novotegra by our sales staff the local conditions are not always sufficiently known, which is why changes to the offered quantities may result during installation. These changes relate mainly to the number of fasteners for the building envelope (for example roof hooks). In this case the additionally required components must always be installed in accordance with the dimensioning.

novotegra GmbH is not liable for incorrect or incomplete data collection sheets. Error-free and fully completed data collection sheets are essential for correct dimensioning.

The information in the mounting instructions, the warranty terms and the information about the liability exclusion must be noted.



novotegra

novotegra GmbH

Eisenbahnstraße 150
72072 Tübingen | Deutschland

Tel. +49 7071 98987-0
Fax +49 7071 98987-10

info@novotegra.com
www.novotegra.com

