

Operating Instructions

Fronius Argono

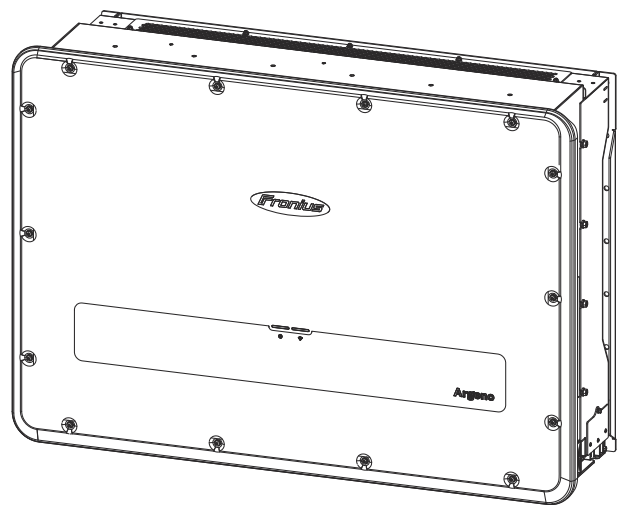

EN-US | Operating instructions



42,0426,0547,EA

002-13032025

Table of contents

Safety rules.....	6
Explanation of Safety Instructions.....	6
General.....	6
Environmental conditions.....	7
Qualified personnel.....	7
Safety measures at the installation site.....	7
Data on noise emission values.....	7
EMC measures.....	7
Data backup.....	8
Copyright.....	8
Equipment grounding (GND).....	8
General information	9
Product description.....	11
Description of the device.....	11
AC Daisy Chain.....	11
Protection of people and equipment.....	12
Safety.....	12
Information on the device.....	12
INV OFF.....	14
Central grid and system protection.....	14
RCMU.....	14
AFCI – arc fault circuit interrupter (ArcGuard).....	14
Safe state.....	15
Utilization in accordance with "intended purpose".....	16
Intended use.....	16
Foreseeable misuse.....	16
Provisions for the photovoltaic system.....	16
Functional principle.....	17
Operating principle.....	17
Overload performance.....	17
Operating controls and connections.....	18
Operating elements and displays.....	18
PV connections.....	19
Data communication area in inverter.....	19
Data communication area.....	19
Button functions and LED status indicators.....	20
Installation and Startup	23
General.....	25
System component compatibility.....	25
Required tools.....	25
Installation location and position.....	26
Choosing the location of the inverter.....	26
Installation position of the inverter.....	28
Installing the inverter.....	29
Selecting the mounting material.....	29
Dimensions of the mounting bracket.....	29
Mounting the inverter on the wall.....	29
Connecting the inverter to the public grid (AC side).....	30
Monitoring the grid.....	30
AC connection area.....	30
Connecting aluminum cables.....	31
Permitted cables.....	31
Maximum alternating current fuse protection.....	31
Safety.....	32
Opening the inverter.....	32
Connecting the inverter to the public grid – Singlecore.....	33

Connecting the inverter to the public grid – PEN conductor.....	34
Connecting the inverter to the public grid – Daisy Chain.....	34
Connecting the PV cable to the inverter.....	36
Safety.....	36
General information about PV modules.....	37
Permitted cables.....	37
Recommended default configuration.....	38
Installing PV plugs.....	40
Connecting PV cables.....	41
Establishing equipotential bonding.....	42
Establishing equipotential bonding.....	42
Connecting the data communication cables.....	43
Permitted cables for the data communication area.....	43
Multiple inverters in a network.....	43
Connecting the LAN cables.....	43
Connecting the ERR alarm relay.....	44
Connecting INV OFF.....	45
First startup.....	46
Closing and switching on the inverter.....	46
Attaching safety stickers (France).....	46
Establishing a local LAN connection.....	47
Establishing a LAN connection via a network.....	47
Starting the inverter for the first time.....	47
Access via Modbus.....	48
De-energizing the inverter and switching it back on.....	49
De-energizing the inverter and switching it back on.....	49
User interface of the inverter	51
General.....	53
Overview.....	53
Update.....	53
Network.....	53
Monitoring.....	54
Monitoring.....	54
Yield.....	56
Configuring via a web interface.....	56
Configuration.....	57
General.....	57
Localization.....	57
AC Settings.....	57
DC Settings.....	66
Communication.....	67
Features / Functions.....	68
Service / Maintenance.....	69
Advanced settings	73
Reactive power control.....	75
Reactive power control.....	75
Operating power range depending on mains voltage.....	75
Dynamics and accuracy.....	75
Reactive power functions.....	76
Parameters for reactive power control.....	79
Effective power control.....	84
Dynamics/accuracy.....	84
Methods for effective power regulation.....	84
P set value.....	84
P limit.....	84
Voltage-dependent power reduction P(U).....	85
P(f).....	87
Parameters for P(f).....	89
Dynamic grid support.....	92

Dynamic grid support (fault ride through).....	92
Dynamic grid support by way of interference immunity.....	92
Dynamic grid support via fast feed-in of residual current.....	92
Parameters for FRT	94
Other grid-supporting functions in the case of effective power	97
Permanent power gradients.....	97
Parameters for permanent power limitation.....	98
Soft start up / power ramp-up limiting.....	98
Power gradient normal operation.....	99
Enhanced island detection	100
Enhanced island detection	100
Enhanced island detection	100
Q on Demand	102
Q on Demand.....	102
Appendix	103
Care and maintenance.....	105
Safety.....	105
General.....	106
Maintenance.....	106
Cleaning	106
Cleaning the fan drawer	106
Status codes and remedy	108
Status codes	108
Technical data.....	110
Argeno 125	110
Explanation of footnotes.....	112
Relevant Standards and Directives.....	113
CE Conformity Marking.....	113
Mains failure.....	113
Service, warranty terms and conditions, and disposal.....	114
Fronius SOS.....	114
Fronius manufacturer's warranty	114
Disposal.....	114
Circuit diagrams and dimensions	115
Dimensions of the mounting bracket.....	116

Safety rules

Explanation of Safety Instructions



DANGER!

Indicates an immediate danger.

- ▶ Death or serious injury may result if appropriate precautions are not taken.



WARNING!

Indicates a possibly dangerous situation.

- ▶ Death or serious injury may result if appropriate precautions are not taken.



CAUTION!

Indicates a situation where damage or injury could occur.

- ▶ Minor injury or damage to property may result if appropriate precautions are not taken.

NOTE!

Indicates the possibility of flawed results and damage to the equipment.

General

The device has been manufactured in line with the state of the art and taking into account recognized safety regulations. If used incorrectly or misused, there is a risk of:

- Serious or fatal injury to the operator or third parties
- Damage to the device and other material assets belonging to the operating company

All personnel involved in device commissioning and maintenance must:

- Be suitably qualified
- Have knowledge of and experience in dealing with electrical installations
- Have fully read and precisely followed these operating instructions

In addition to the operating instructions, all applicable local regulations regarding accident prevention and environmental protection must also be followed.

All safety and danger notices on the device:

- Must be kept in a legible state
- Must not be damaged
- Must not be removed
- Must not be covered, have anything stuck on them, or painted over

Only operate the device when all safety devices are fully functional. If the safety devices are not fully functional, there is a danger of:

- Serious or fatal injury to the operator or third parties
- Damage to the device and other material assets belonging to the operating company

Any safety devices that are not fully functional must be repaired by an authorized specialist before the device is switched on.

Never bypass or disable safety devices.

For the location of the safety and danger notices on the device, refer to the chapter headed "Information on the device" in the operating instructions for your device.

Any equipment malfunctions which impair safety must be remedied before the device is turned on.

Environmental conditions

Operation or storage of the device outside the stipulated area will be deemed as not in accordance with the intended purpose. The manufacturer accepts no liability for any damage resulting from improper use.

Qualified personnel

The information contained in these operating instructions is intended only for qualified personnel. An electric shock can be fatal. Do not carry out any actions other than those described in the documentation. This also applies to qualified personnel.

All cables must be secured, undamaged, insulated, and adequately dimensioned. Loose connections, damaged or under-dimensioned cables must be repaired immediately by an authorized specialist company.

Maintenance and repair work must only be carried out by an authorized specialist company.

It is impossible to guarantee that third-party parts are designed and manufactured to meet the demands made on them, or that they satisfy safety requirements. Only use original spare parts.

Do not carry out any alterations, installations, or modifications to the device without first obtaining the manufacturer's permission.

Replace any damaged components or have them replaced immediately.

Safety measures at the installation site

When installing devices with ventilation slots, ensure that the ambient air can enter and exit unhindered through the vents. When selecting the installation site, observe the protection class (IP).

Data on noise emission values

The sound pressure level of the inverter is indicated in the [Technical data](#).

The cooling of the device takes place via an electronic temperature control system at the lowest possible noise level and depends on the power used, ambient temperature, and the soiling level of the device, etc.

It is not possible to provide a workplace-related emission value for this device, because the actual sound pressure level is heavily influenced by the installation situation, the power quality, the surrounding walls, and the properties of the room in general.

EMC measures

In certain cases, even though a device complies with the standard limit values for emissions, it may affect the application area for which it was designed (e.g., when there is equipment that is susceptible to interference at the same location or if the site where the device is installed is close to either radio or television receivers). If this is the case, the operator is obliged to take action to rectify the situation.

Data backup

With regard to data security, the user is responsible for:

- backing up any changes made to the factory settings
- saving and storing personal settings

Copyright

Copyright of these operating instructions remains with the manufacturer.

Text and illustrations were accurate at the time of printing, subject to change. We are grateful for suggestions for improvement and information on any discrepancies in the operating instructions.

Equipment grounding (GND)

Grounding a point in the device, system, or installation serves as a protective measure against electric shock in the event of a fault. When installing an inverter from safety class 1 (see [Technical data](#)), a ground conductor connection is required.

When connecting the ground conductor, ensure that it is secured to prevent unintentional disconnection. All of the points listed in the chapter headed [Connecting the inverter to the public grid \(AC side\)](#) on page 30 must be observed. When using strain-relief devices, it is important to ensure that the ground conductor is loaded last in the event of a failure. The respective national standards and regulations and requirements for minimum cross-section must be observed when connecting the ground conductor.

General information

Product description

Description of the device

The inverter transforms the direct current generated by the PV modules into alternating current. This alternating current is fed into the public grid and synchronized with the mains voltage in use.

The inverter has been designed exclusively for use in grid-connected photovoltaic systems. It cannot generate electric power independently of the grid.

The inverter also has a design and functions that ensure it can offer maximum safety during installation and during operation.

AC Daisy Chain

With the "AC Daisy Chain" inverter variant, the AC lead can be routed directly from the inverter to another inverter. This makes it possible to quickly connect a maximum of two Argeno inverters to each other. The optionally available Daisy Chain input plate and type 2 AC SPDs are required for this variant.

The minimum cable cross-section is defined based on the fuse on the grid connection point. A larger cable cross-section can be selected at any time. The applicable standards in the respective country must be taken into account and followed.

Protection of people and equipment

Safety

WARNING!

Danger due to incorrect operation and incorrectly performed work.

This can result in serious injury and damage to property.

- ▶ All the work and functions described in this document must only be carried out by trained and qualified personnel.
- ▶ Read and understand this document.
- ▶ Read and understand all the Operating Instructions for the system components, especially the safety rules.

WARNING!

Danger from electromagnetic fields. Electromagnetic fields are generated during operation.

Effects on the health of persons (e.g., those wearing a pacemaker) can result.

- ▶ Do not remain closer than 20 cm from the inverter for a prolonged period of time.

Information on the device

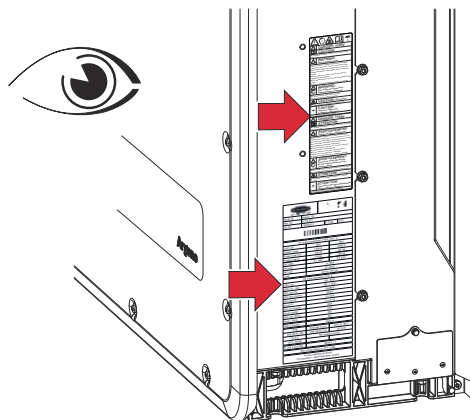

Warning notices and safety symbols can be found on and in the inverter. These must not be removed or painted over. The notices and symbols warn against incorrect operation, as this may result in serious injury and damage to property.

Symbols on the rating plate:



CE label – confirms compliance with applicable EU directives and regulations.



WEEE marking – waste electrical and electronic equipment must be collected separately and recycled in an environmentally sound manner in accordance with the European Directive and national law.

Safety symbols and text:



DANGER: 1100V
GEFAHR: 1100V

WARNING: Risk of Electric Shock

Both AC and DC voltage sources are terminated inside this equipment. The DC conductors of this photovoltaic system are ungrounded and may be energized when the photovoltaic array is exposed to light.

- Before removing cover, each circuit must be individually disconnected.
- Do not remove cover. No user serviceable parts inside.
- Refer Servicing To Qualified Service Personnel.

Translation:

WARNING: Risk of Electric Shock

Both AC and DC voltage sources are terminated inside this equipment. The DC conductors of this photovoltaic system are ungrounded and may be energized when the photovoltaic array is exposed to light.

- Before removing cover, each circuit must be individually disconnected.
- Do not remove cover. No user serviceable parts inside.
- Refer Servicing To Qualified Service Personnel.



CAUTION: Read IMPORTANT SAFETY INSTRUCTIONS before Use.

Translation:

CAUTION: Read IMPORTANT SAFETY INSTRUCTIONS before Use.

Do not use the functions described here until you have fully read and understood the following documents:

- These operating instructions.
- All operating instructions for the system components of the photovoltaic system, especially the safety rules.



CAUTION: Hot Surface

- To reduce the risk of burns - Do not touch.

Translation:

CAUTION: Hot Surface

- To reduce the risk of burns - Do not touch.



WARNING: Risk of electric shock from stored energy in capacitor

- Do not remove cover until 5 min after disconnecting all sources of supply.

Translation:

WARNING: Risk of electric shock from stored energy in capacitor

- Do not remove cover until 5 min after disconnecting all sources of supply.

Safety symbols and text:



CAUTION: Ingress of water may damage the electronic
- Do not open unit when it rains.

Translation:

CAUTION: Ingress of water may damage the electronic
- Do not open unit when it rains.

INV OFF

The wired shutdown INV OFF interrupts the inverter's grid power feed if the trigger device (INV OFF) has been activated.

For installation, see [Connecting INV OFF](#) on page 45.

Central grid and system protection

The inverter offers the option to use the integrated AC relays as section switches in conjunction with a central grid and system protection unit (in accordance with VDE-AR-N 4105:2018:11 §6.4.1). For this purpose, the central trigger device (switch) must be integrated into the WSD chain as described in chapter [INV OFF](#) on page 14.

RCMU

The inverter is equipped with an RCMU (residual current monitoring unit) according to IEC 62109-2 and VDE 0126-1-1. It monitors residual currents from the PV module up to the AC output of the inverter and disconnects the inverter from the grid if an impermissible residual current is detected. If the RCMU is not working properly, the device will be immediately disconnected from the public grid at all poles.

AFCI – arc fault circuit interrupter (ArcGuard)

A Fronius Argento version is available with AFCI (arc fault circuit interrupter) arc detection (item number: 4,210,471).

An AFCI protects against arc faults and, in the narrower sense, is a protection device in the event of contact faults. The AFCI evaluates faults that occur in the current and voltage flow using an electronic circuit and shuts down the circuit if a contact fault is detected. This prevents overheating and possible fires at poor contact points.

IMPORTANT!

Active PV module electronics can impair the function of the ArcGuard. Fronius cannot guarantee correct function when using the Fronius ArcGuard in combination with active PV module electronics.



CAUTION!

Danger from faulty or incorrect DC installation.

This may result in a risk of damage and, as a consequence, risk of fire in the PV system due to prohibited thermal loads that occur during an arc.

- ▶ Check the plug connections to ensure that they are correct.
- ▶ Repair faulty insulation correctly.
- ▶ Perform connection work in line with the instructions.

IMPORTANT!

Fronius will not bear any costs which may arise due to a detected electric arc and its consequences. Fronius accepts no liability for damage which may occur despite the integrated arc fault circuit interrupter/interruption (e.g., due to a parallel arc).

Safe state

If one of the following safety devices is triggered, the inverter switches to the safe state:

- INV OFF
- Isolation measurement and
- RCMU

In the safe state, the inverter no longer feeds in and is disconnected from the grid by the opening of the AC relay.

Utilization in accordance with "intended purpose"

Intended use The inverter is designed exclusively to convert direct current from PV modules into alternating current and feed this power into the public grid.

Intended use also includes following all information from the operating instructions.

Foreseeable misuse The following circumstances are considered to be reasonably foreseeable misuse:

- Any use that is not the intended use or goes beyond the intended use.
- Alternations to the inverter are not expressly recommended by Fronius.
- Installation of components that are not expressly recommended or sold by Fronius.

The manufacturer shall not be liable for any resulting damage. In addition, no warranty claims will be entertained.

Provisions for the photovoltaic system The inverter is designed exclusively to be connected and used with PV modules. Use with other DC generators (e.g., wind generators) is not permitted.

When configuring the photovoltaic system, make sure that all photovoltaic system components are operating exclusively within their permitted operating range.

All measures recommended by the PV module manufacturer for maintaining the PV module properties must be followed.

Functional principle

Operating principle

The inverter is fully automatic. Starting at sunrise, as soon as the PV modules are generating enough energy, the inverter starts checking the PV system (insulation measurement) and the grid (mains voltage and mains frequency). If all values are within the normative framework, the system is automatically connected to the grid and grid power feed operation begins.

The control system of the inverter ensures that the maximum possible power output is drawn from the PV modules at all times. This function is called MPPT (Maximum Power Point Tracking). In the event of shady conditions affecting the PV modules, a large part of the local maximum power point (LMPP) of the PV system can still be obtained via the "Dynamic Peak Manager" function.

As dusk starts and there is no longer sufficient energy available to feed energy into the grid, the inverter shuts down the connection of the power electronics to the grid completely and stops operating. All settings and recorded data are saved.

Overload performance

When the device temperature gets too high, the inverter automatically reduces the current output power in order to protect itself. Reasons for an excessively high device temperature can be a high ambient temperature or insufficient heat dissipation (for example, when installed in containers without sufficient heat dissipation).

The output of the inverter is reduced such that the temperature will not exceed the permissible limit.

If a maximum temperature is exceeded, the inverter switches off in a safe state and resumes grid power feed operation only after the device has cooled down.

Operating controls and connections

Operating elements and displays

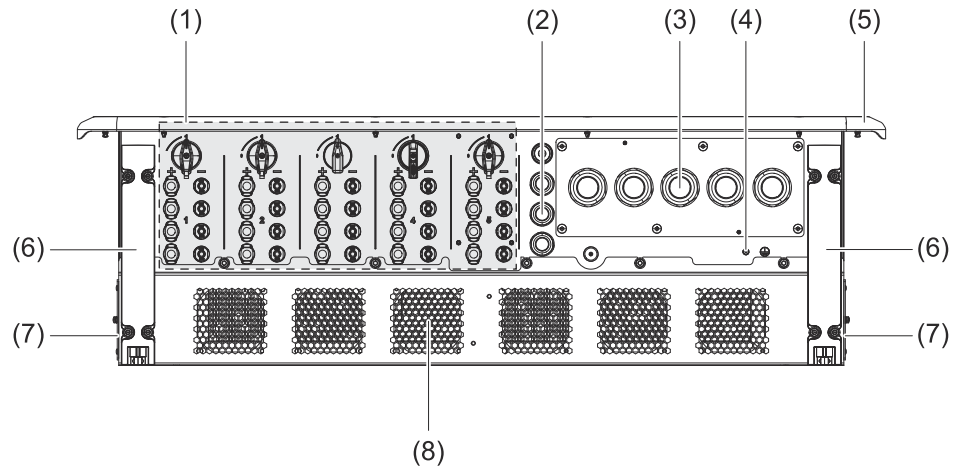

- (1) DC disconnectors and DC connections
- (2) Cable glands for data communication
- (3) Cable glands for AC
- (4) Connection bolt for grounding
- (5) Housing cover
- (6) Support foot with handle (left/right)
- (7) Fan drawer (left/right)
- (8) Fan

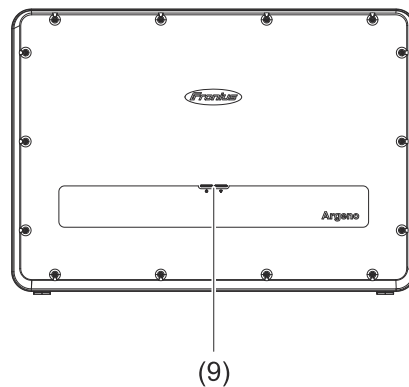

- (9) LED status indicators
For further information on the LED status indicators, see [Button functions and LED status indicators](#)

PV connections

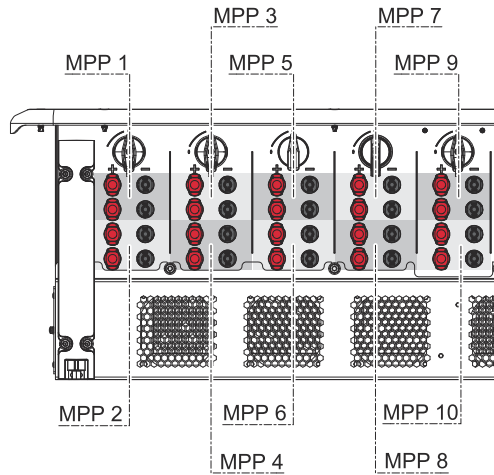

Data communication area in inverter

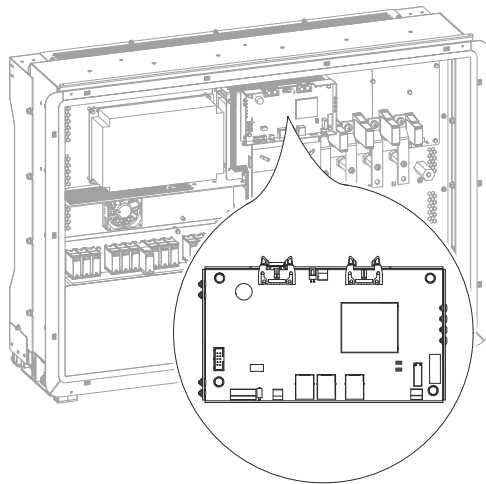

The data communication area is located in the middle of the inverter.

Data communication area

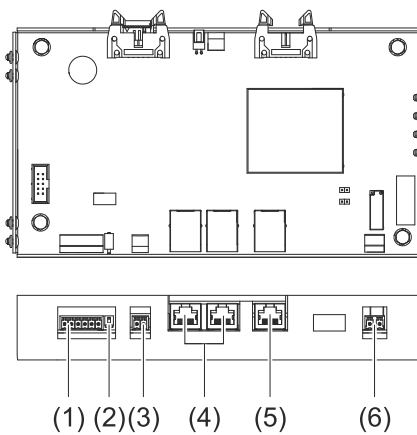

(1)	RS485 interface Reserved for future functions.
(2)	RS485 switch
(3)	INV OFF Connection for external 24 V (+/-20%) / 1 A (min. 15 mA) grid protection component, see Connecting INV OFF on page 45.

(4)	LAN1 and 2 Ethernet connection for data communication (e.g., WLAN router, home network, or for commissioning with a laptop, see chapter Establishing a LAN connection via a network on page 47).
(5)	LAN direct Ethernet connection for commissioning with static IP (direct PC connection), see Establishing a local LAN connection on page 47.
(6)	ERR error message relay The relay contact closes as soon as a malfunction occurs. This function can be used to indicate an error via a visible or audible signal. For installation, see Connecting the ERR alarm relay on page 44.

Button functions and LED status indicators

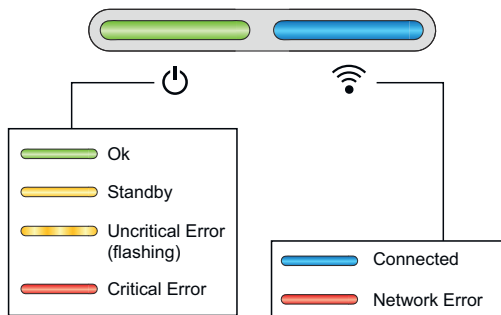

The operating status LED displays the status of the inverter.



The communications LED displays the connection status.

LED status indicators

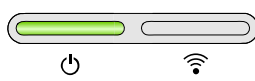

The inverter is operating correctly.

⏻ Lights up green



The inverter is starting.

⏻ Flashes green



The inverter is on standby, is not operating (e.g., no grid feed-in at night), or is not configured.

⏻ Lights up yellow

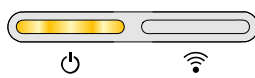

The inverter displays a non-critical status.

⏻ Flashes yellow

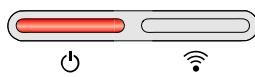

The inverter displays a critical status and no grid feed-in process is taking place.

⏻ Lights up red

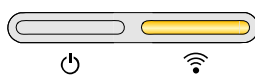

The network connection is not configured.

📶 Lights up yellow

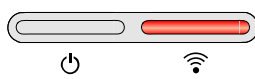

A network error is displayed, the inverter is operating correctly.

📶 Lights up red

LED status indicators



The inverter is performing an update.

⏻ / 📶 Flash blue

Installation and Startup

General

System component compatibility

All components installed in the photovoltaic system must be compatible and have the necessary configuration options. The installed components must not restrict or negatively influence the functioning of the photovoltaic system.

NOTE!

Risk due to components in the photovoltaic system that are not compatible and/or have limited compatibility.

Incompatible components may limit and/or negatively affect the operation and/or functioning of the photovoltaic system.

- ▶ Only install components recommended by the manufacturer in the photovoltaic system.
- ▶ Before installation, check the compatibility of components not expressly recommended with the manufacturer.

Required tools

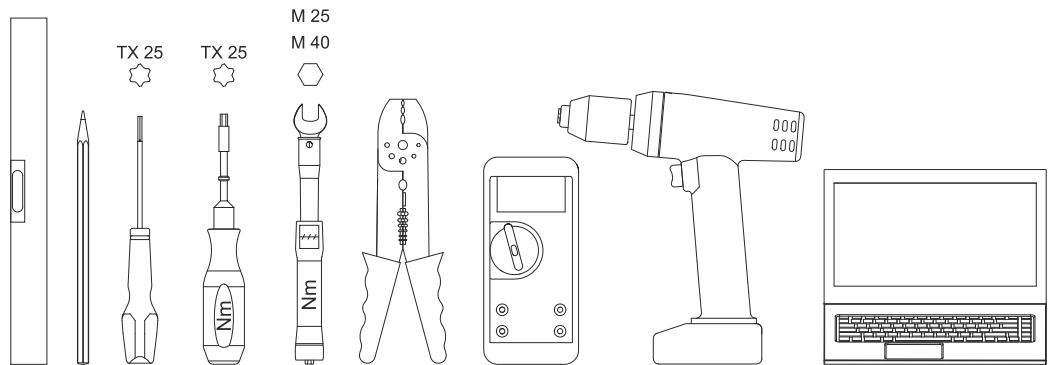

- Spirit level
- Pencil
- Screwdriver TX25
- Torque wrench TX25
- Torque wrench M25, M40
- Stripping tool for wires and cables
- Multimeter for measuring voltage
- Drill driver
- Computer for setting up the inverter

Installation location and position

Choosing the location of the inverter

DANGER!

Danger due to flammable or explosive materials in the vicinity of the device.

Fire poses a risk of serious or fatal injury.

- ▶ Do not install the device in potentially explosive atmospheres or in the vicinity of highly flammable materials.

CAUTION!

Improper positioning can cause condensate to build up in the device and impair its function (e.g., if the device is positioned in areas outside the specified ambient conditions or moved from a cold to a warm environment on a short-term basis).

Material damage due to build-up of condensate.

- ▶ Check interior for condensate prior to electrical installation and allow adequate drying time if necessary.
- ▶ Position the device in accordance with the technical data.

CAUTION!

The device housing can be severely damaged due to gases in conjunction with weather-related humidity (e.g., ammonia, sulfur).

Damage to property due to gases that react aggressively on surfaces in conjunction with weather-related humidity.

- ▶ If the device is exposed to gases, it must be set up at a location where it can be checked.
- ▶ Carry out regular visual inspections.
- ▶ Remove moisture on the housing immediately.
- ▶ Ensure adequate ventilation at the setup location.
- ▶ Remove soiling immediately, especially on vents.
- ▶ Damage to the device resulting from failure to observe these instructions is not covered by the warranty.

Please note the following criteria when choosing a location for the inverter:

Only install on a solid, non-flammable surface

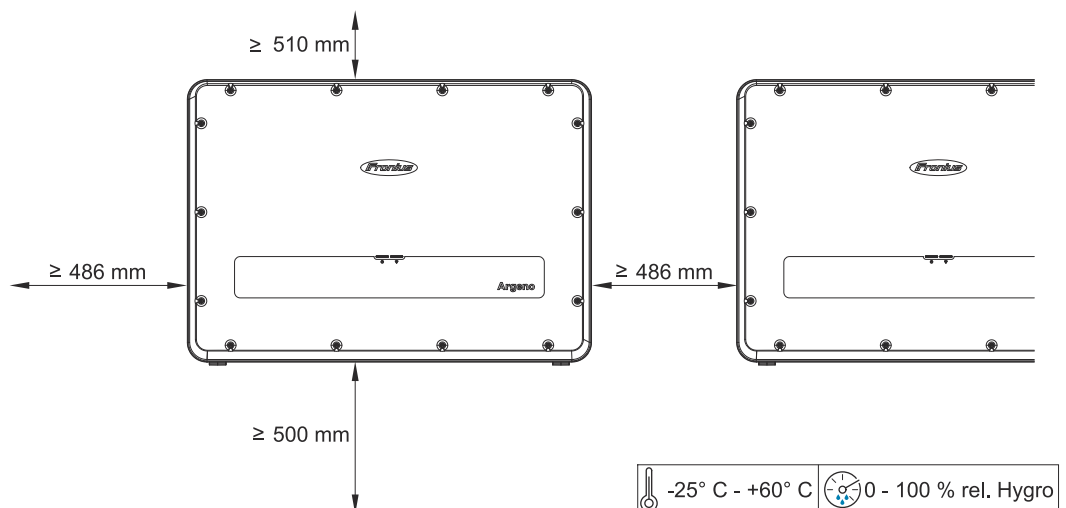

When installing the inverter in a switch cabinet or similar closed environment, ensure adequate heat dissipation by forced-air ventilation.

When installing the inverter on the outer walls of cattle sheds, it is important to maintain a minimum clearance of 2 m between all sides of the inverter and the ventilation and building openings.

The following substrates are allowed:

- Wall installation: Corrugated sheet metal (mounting rails), brick, concrete, or other non-flammable surfaces sufficiently capable of bearing loads
 - Pole mounted: Mounting rails, behind the PV modules directly on the PV mounting system
 - Flat roofs (if a film roof, make sure that the films comply with the fire protection requirements and are not highly flammable. Ensure compliance with the national provisions.)
 - Covered parking lot roof (no overhead installation)
-

The DC disconnectors must always be freely accessible after installation of the inverter.



The inverter is suitable for indoor installation.



The inverter is suitable for outdoor installation.

Due to its IP 66 protection class, the inverter is not susceptible to water spray from any direction.



Do not expose the inverter to direct sunlight in order to keep inverter heating as low as possible.



The inverter should be installed in a protected location, e.g., near the PV modules or under an overhanging roof.

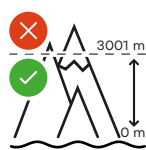

The inverter must not be installed or operated at more than 3,000 m above sea level.



Do not install the inverter:

- Where it may be exposed to ammonia, corrosive gases, acids, or salts (e.g., fertilizer storage areas, vent openings for livestock stables, chemical plants, tanneries, etc.)
-



Caution: This device is not intended for use in living environments and may not provide sufficient protection for radio reception in such environments.

This device is intended for use at locations that are at least 30 m away from any sensitive wireless services belonging to third parties.

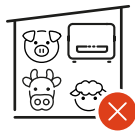

Do not install the inverter in:

- Areas where there is an increased risk of accidents from farm animals (horses, cattle, sheep, pigs, etc.)
- Stables or adjoining areas
- Storage areas for hay, straw, chaff, animal feed, fertilizers, etc.



The inverter is designed to be dust-proof (IP 66). In areas of high dust accumulation, dust deposits may collect on the cooling surfaces, and thus impair the thermal performance. Regular cleaning is necessary in such situations. We therefore recommend not installing the inverter in areas and environments with high dust accumulation.



Do not install the inverter in:

- Greenhouses
- Storage or processing areas for fruit, vegetables, or viticulture products
- Areas used in the preparation of grain, green fodder, or animal feeds

Installation position of the inverter

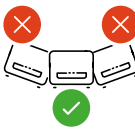

The inverter is suitable for vertical installation on a vertical wall or column.

Do not install the inverter:

- In a tilted position
-
- With the connections pointing upwards
- On feet

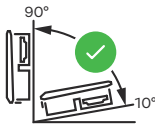

The inverter is suitable for a horizontal installation position or installation on a sloping surface.

Do not install the inverter:

- On a sloping surface with the connections pointing upwards
- Overhanging with the connections pointing downwards
- On the ceiling

Installing the inverter

Selecting the mounting material

WARNING!

Using unsuitable mounting material can cause the device to fall.

This can result in personal injury.

- ▶ Only use mounting material suitable for the mounting surface. Only use the supplied mounting material for masonry and concrete.
- ▶ Only mount the device in a suspended upright position.

Use the corresponding mounting material depending on the subsurface and observe the screw dimension recommendations for the mounting bracket. The installer is responsible for selecting the right type of mounting material.

Dimensions of the mounting bracket

The dimensions of the mounting bracket can be found on page [116](#) at the end of the document.

Mounting the inverter on the wall

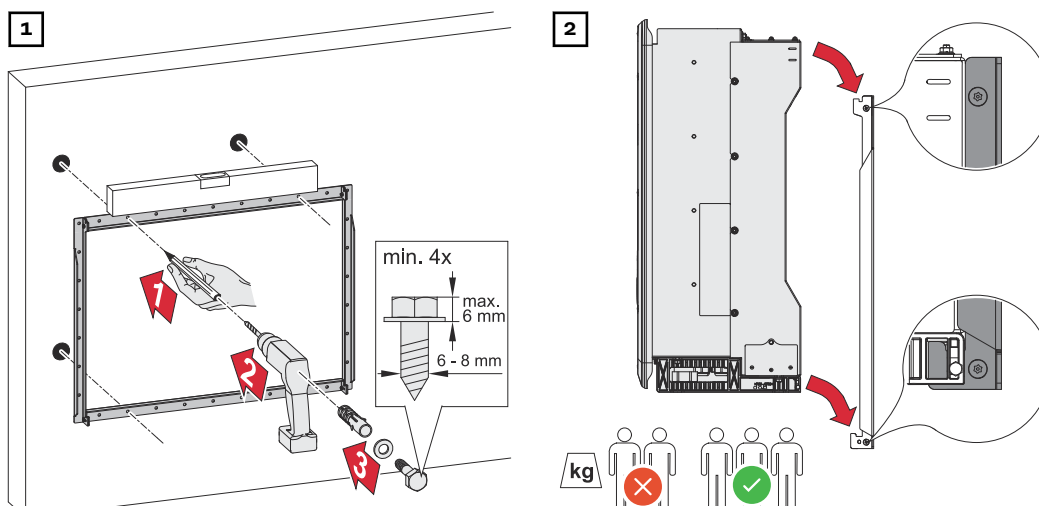

Connecting the inverter to the public grid (AC side)

Monitoring the grid

IMPORTANT! To provide the best possible grid monitoring, the resistance in the leads to the mains connections should be as low as possible.

AC connection area

Singlecore cable gland version

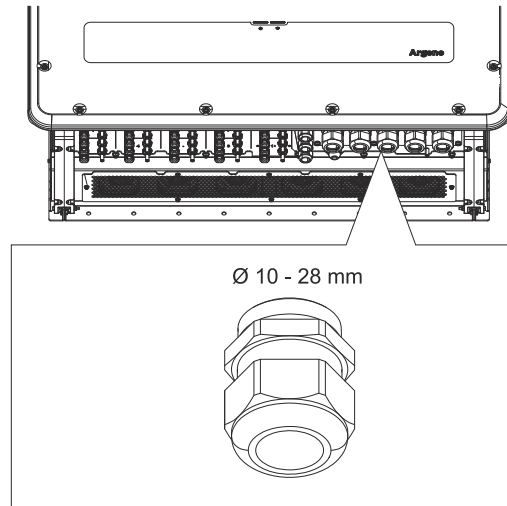

5x M40 cable glands
Diameter: 10-28 mm

Multicore cable gland version

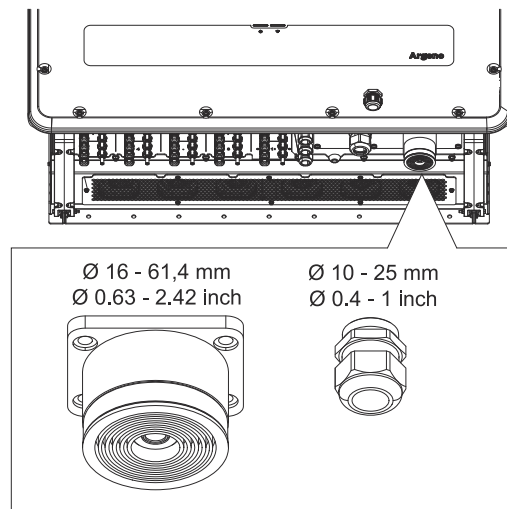

The following cable outer diameters can be used with the larger cable gland:
16-61.4 mm

Grounding cables measuring 10-25 mm can be routed through the small cable gland (M32 cable gland).

AC Daisy Chain cable gland version

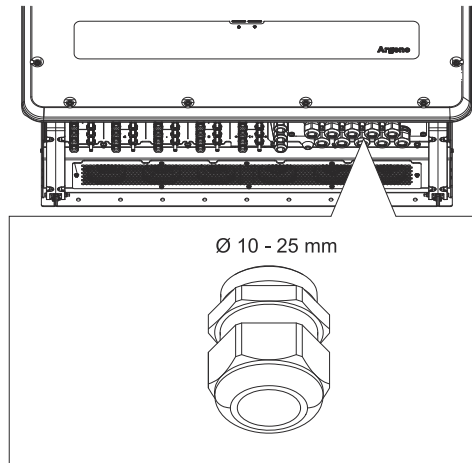

10x M40 cable glands
Diameter: 10-28 mm

Connecting aluminum cables

Aluminum cables can be connected to the AC connections.

⚠ DANGER!

If electrolytes are present (e.g., condensate), the aluminum can be destroyed by the copper busbar.

Fire poses a risk of serious or fatal injury.

- ▶ Cable lugs must be suitable for the conductor material and copper busbars used.
- ▶ When using aluminum cable lugs, select cable lugs with electroplating or AL/CU cable lugs and matching AL/CU washers.

NOTE!

When using aluminum cables:

- ▶ Follow all national and international guidelines regarding the connection of aluminum cables.
- ▶ Grease aluminum wires with appropriate grease to protect them from oxidation.
- ▶ Follow the instructions provided by the cable manufacturer.

Permitted cables

Select cross-sections of sufficient size depending on the power category and connection version!

Power category	Connection version	Cable cross-section
Argeno 125	Singlecore	50-240 mm ²
	Multicore	50-240 mm ²
	Daisy Chain	50-240 mm ²

Maximum alternating current fuse protection

If an external residual current circuit breaker is required due to installation regulations, a type A residual current circuit breaker must be used.

If a type B residual current circuit breaker is used, the **Compliant with type B**

RCD menu item must be enabled.

If one of these types is used, it must have a protective rating of at least 1,250 mA.

NOTE!

The inverter may be used with a maximum 500 A automatic circuit breaker.

Safety

⚠ WARNING!

Danger from mains voltage and DC voltage from PV modules.

An electric shock can be fatal.

- ▶ Prior to any connection work, ensure that the inverter is de-energized on the AC side and the DC side.
- ▶ Only an authorized electrical engineer is permitted to connect this equipment to the public grid.

⚠ CAUTION!

Danger of damaging the inverter due to improperly connected wires.

Improperly connected wires can cause thermal damage to the inverter and may cause a fire.

- ▶ When connecting AC and DC wires, make sure that all cables are secured to the inverter connections using the correct torque.

IMPORTANT! For the PE connection, the requirements defined under "Safety rules" for safe connection of the PE conductor must also be observed.

Opening the inverter

⚠ CAUTION!

Components inside the device can be irreparably damaged by static discharge.

Damage to the device due to electrostatic discharge.

- ▶ Observe the ESD protection measures.
- ▶ Before touching a component, ground it by touching an earthed object.

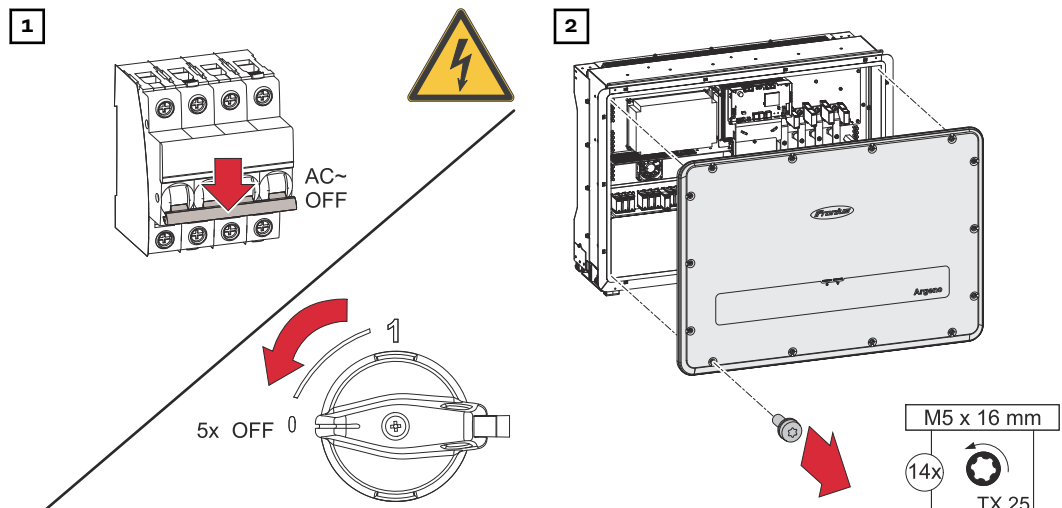

Connecting the inverter to the public grid – Singlecore

The phases should be connected in the proper order: L1, L2, L3, N, and PE.

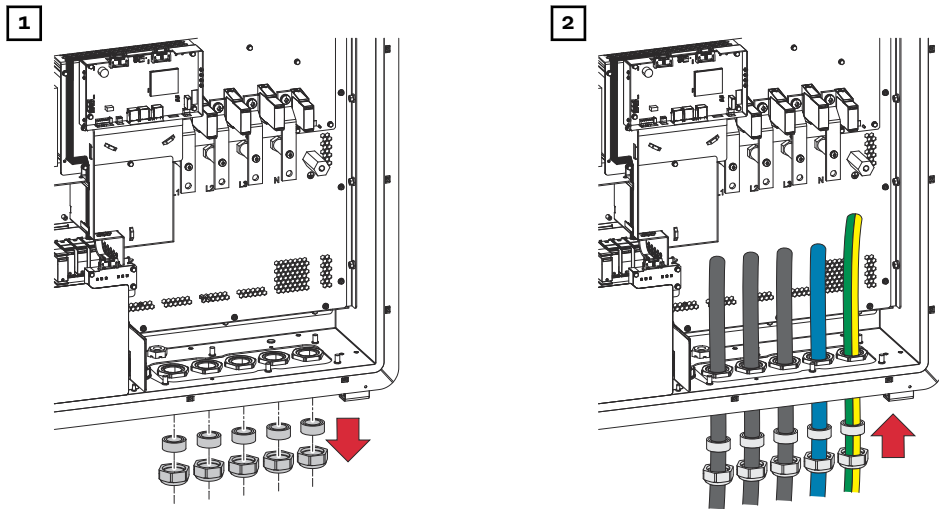

⚠ CAUTION!

Short circuits may damage the inverter.

AC leads that are not installed and routed correctly can result in damage to the device.

- ▶ Insulate bare parts of the connection cable and cable lug, e.g., using shrink sleeve.
- ▶ Connect the AC leads with as much distance between them as possible.

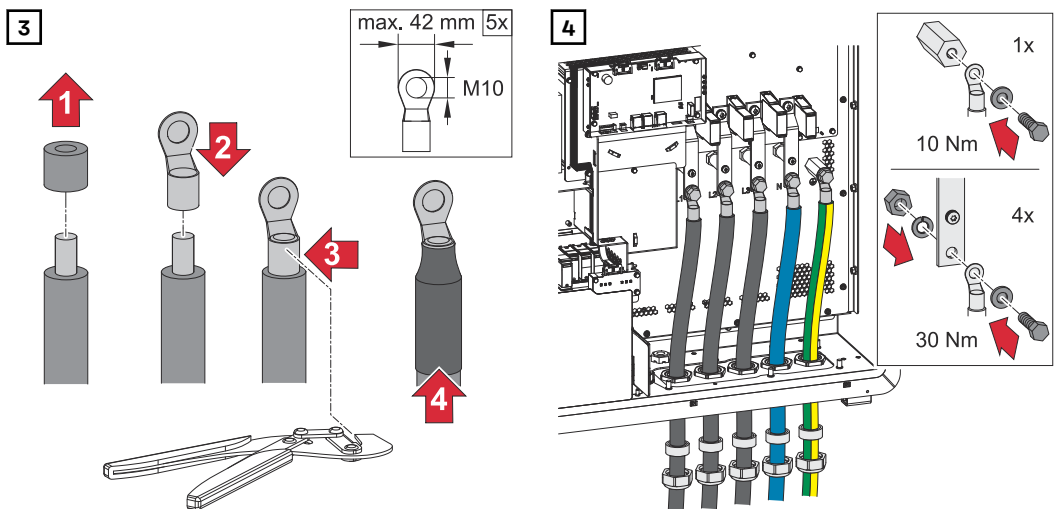

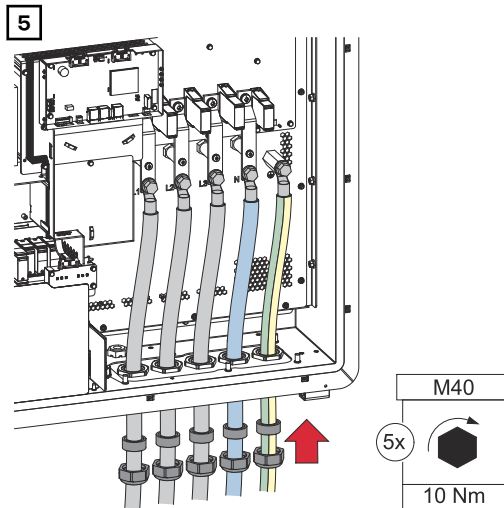

Connecting the inverter to the public grid – PEN conductor

The connection process corresponds to that of the **Singlecore** version, see [Connecting the inverter to the public grid – Singlecore](#) on page 33.

⚠ CAUTION!

Short circuits may damage the inverter.

AC leads that are not installed and routed correctly can result in damage to the device.

- ▶ Insulate bare parts of the connection cable and cable lug, e.g., using shrink sleeve.
- ▶ Connect the AC leads with as much distance between them as possible.

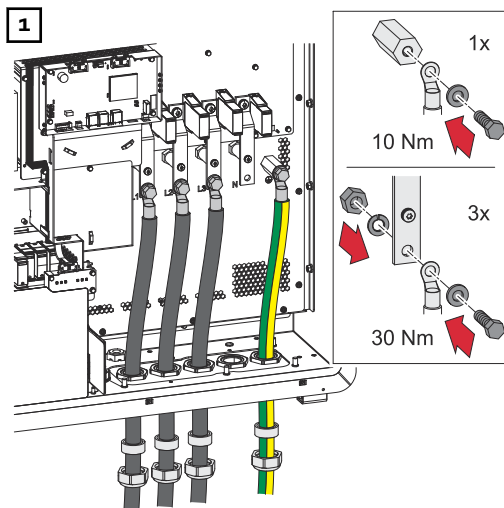

The cable gland of the N conductor that is not being used must be closed.

Connecting the inverter to the public grid – Daisy Chain

The connection process corresponds to that of the **Singlecore** version, see [Connecting the inverter to the public grid – Singlecore](#) on page 33.

The optionally available **AC input plate - Daisy Chain** is required to connect the **Daisy Chain** version.

⚠ CAUTION!

Short circuits may damage the inverter.

AC leads that are not installed and routed correctly can result in damage to the device.

- ▶ Insulate bare parts of the connection cable and cable lug, e.g., using shrink sleeve.
- ▶ Connect the AC leads with as much distance between them as possible.

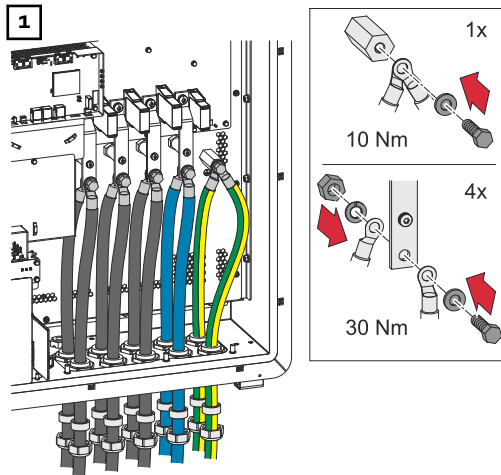

The L1 / L2 / L3 / N leads are connected to the front and rear of the busbar in each case. The groundings are connected to the PE connection.

Connecting the PV cable to the inverter

Safety



DANGER!

DC voltage is present at the exposed ends of the DC leads when there is irradiation on the PV modules.

Touching the live connections can result in severe injury or death.

- ▶ Only touch insulated parts of the PV module leads. Do not touch exposed lead ends.
- ▶ Avoid short circuits.
- ▶ Do not connect shorted strings to the device.
- ▶ The device must not be operated with PV modules with a negative or positive ground.



DANGER!

Danger from mains voltage and DC voltage of PV modules that are exposed to light.

An electric shock can be fatal.

- ▶ Prior to any connection work, ensure that the inverter is de-energized on the AC side and the DC side.
- ▶ Only an authorized electrical engineer is permitted to connect this equipment to the public grid.



WARNING!

Danger of an electric shock due to improperly connected terminals/PV plug connectors.

An electric shock can be fatal.

- ▶ When connecting, ensure that each pole of a string is routed via the same PV input, e.g.:
+ pole string 1 to the input **PV 1.1+** and **- pole string 1** to the input **PV 1.1-**



WARNING!

Danger from DC voltage. Even if the DC disconnectors are switched off, the fuse PCB and everything before the DC disconnectors are live.

An electric shock can be fatal.

- ▶ Prior to any connection work, ensure that the inverter is de-energized on the AC side and the DC side.



CAUTION!

Danger due to polarity reversal at the terminals.

This may result in severe damage to the inverter.

- ▶ Use a suitable measuring instrument to check the polarity of the DC cabling.
- ▶ Use a suitable measuring instrument to check the voltage.



CAUTION!

Risk of damage to the inverter by exceeding the maximum input current per string.

Exceeding the maximum input current per string can damage the inverter.

- ▶ Observe the maximum input current per string for the inverter according to the technical data.
- ▶ The maximum input current must not be exceeded even when using Y or T plugs.

General information about PV modules

To enable suitable PV modules to be chosen and to use the inverter as efficiently as possible, it is important to bear the following points in mind:

- If insolation is constant and the temperature is falling, the open-circuit voltage of the PV modules will increase. The open-circuit voltage must not exceed the max. permissible system voltage. An open-circuit voltage above the indicated values will damage the inverter, and all warranty rights will become null and void.
- The temperature coefficients on the data sheet of the PV modules must be observed.
- Exact values for sizing the PV modules can be obtained using suitable calculation tools, such as the [Fronius Solar.creator](#).

IMPORTANT!

Before connecting up the PV modules, check that the voltage for the PV modules specified by the manufacturer corresponds to the actual measured voltage.



IMPORTANT!

The PV modules connected to the inverter must comply with the IEC 61730 Class A standard.

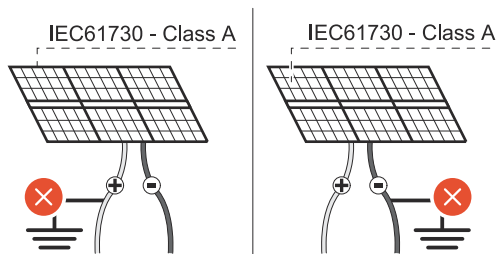

IMPORTANT!

Solar module strings must not be grounded.

max. 1100 V_{DC}

Permitted cables

Select cable cross-sections of sufficient size depending on the device type.

Power category	Adapter	Cable cross-section
Argeno 125	Phoenix/PV-C3F-S 2.5-6 (+) 1,100 V/35 A	2.5-6 mm ² (see data sheet of the plug)
	Phoenix/PV-C3M-S 2.5-6 (-) 1,100 V/35 A	

Recommended default configuration

All DC inputs disconnected

IMPORTANT! String fuses may be required depending on the selected PV modules. Observe the information provided by the manufacturer of the module.

Two strings on one MPP tracker

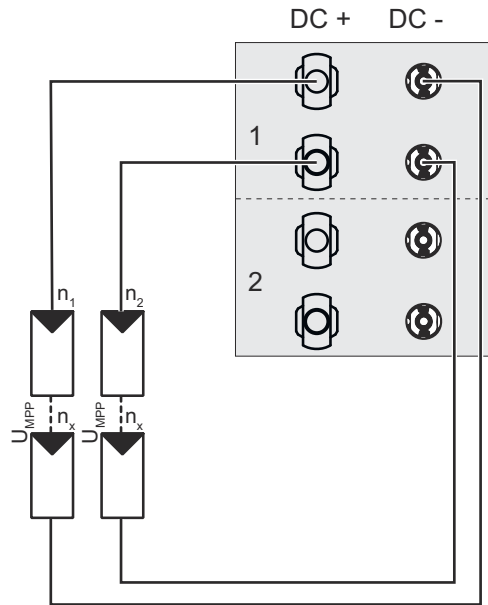

Two strings on an MPP tracker

Restriction:

Max. 15 A per plug /
Max. 30 A per MPP tracker

One string on one MPP tracker

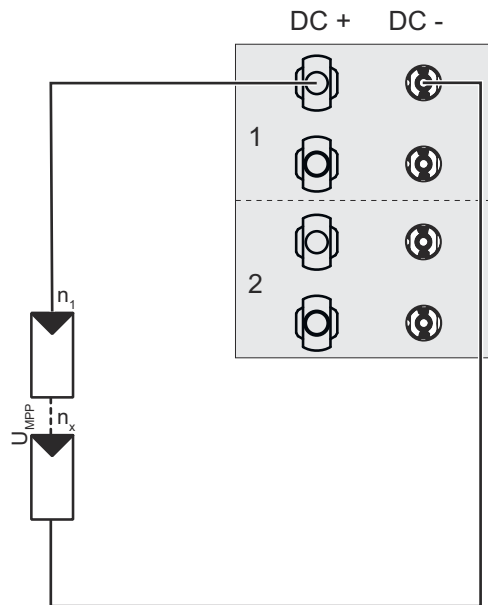

One string on an MPP tracker

Restriction:

Max. 20 A per plug and MPP tracker

Two strings via Y cables and one string directly on one MPP tracker

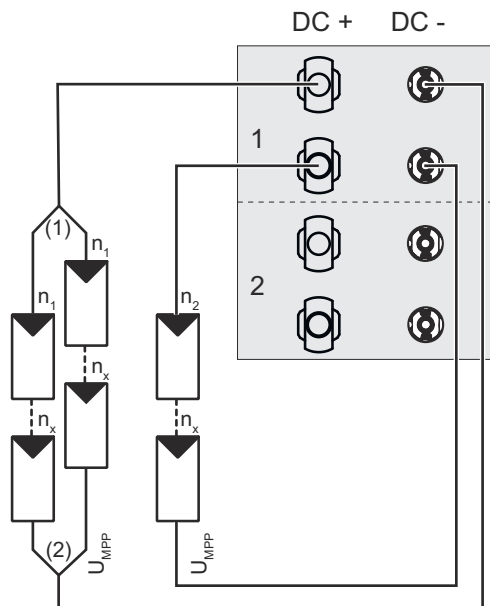

Two strings via Y cables and one string directly on an MPP tracker

Restriction:

Max. 10 A per string on the Y cable /
Max. 30 A on the MPP tracker

Required accessories:

Min. two Y cables (one PV+ / PV-
each) for a string

(1) PD-ED6/Y-120 (1+/2-)

(2) PD-ED6/Y-120 (2+/1-)

Two strings via Y cables on one MPP tracker

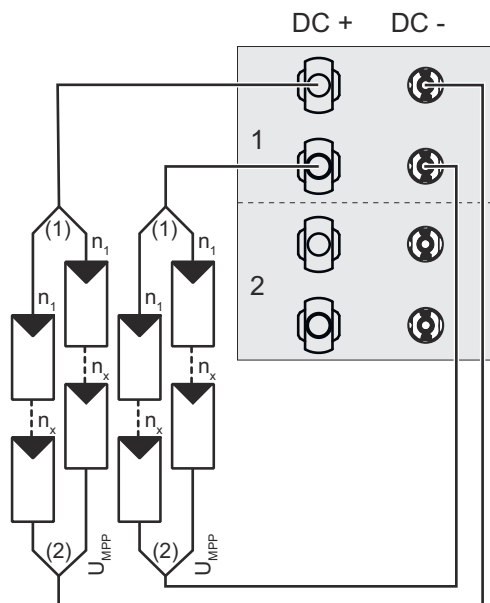

Two strings via Y cables directly on an MPP tracker

Restriction:

Max. 7.5 A per string on the Y cable /
Max. 30 A on the MPP tracker

Required accessories:

Min. four Y cables (1 PV+ / PV-
each) for a string

(1) PD-ED6/Y-120 (1+/2-)

(2) PD-ED6/Y-120 (2+/1-)

All DC inputs parallel (All inputs parallel)

When the All inputs parallel function is enabled, the current is restricted to 20 A per plug and 60 A per interconnected MPP tracker.



WARNING!

Damage to the device due to overloaded DC plug connections

In parallel DC operation, the device is not designed for a current of more than 20 A per DC plug connection.

- Each DC plug connection must not exceed a current of 20 A.

IMPORTANT! String fuses may be required depending on the selected PV modules. Observe the information provided by the manufacturer of the module.

One parallel string via two MPP trackers and one separated string each per MPP tracker

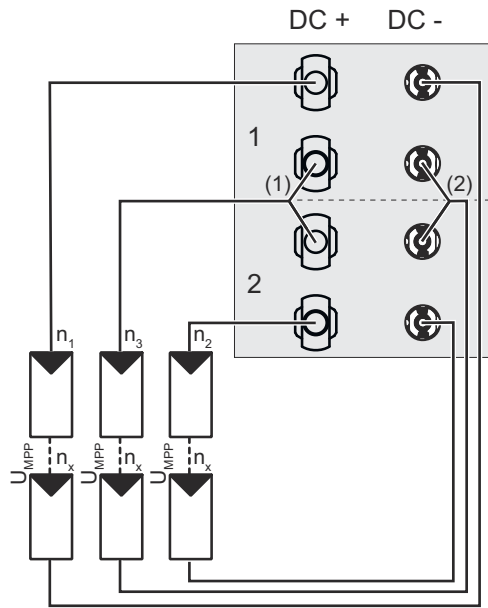

One string parallel via two MPP trackers and one separated string on each MPP tracker

Restriction:

Max. 20 A on the Y plug (n₃) and 20 A each on the plug (MPP tracker 1/n₁ and MPP tracker 2/n₂)
Max. 30 A per MPP tracker

Required accessories:

10x Y cable (1x PV- / PV+)

- (1) PD-ED6/Y-120 (2+/1-)
- (2) PD-ED6/Y-120 (1+/2-)

Installing PV plugs

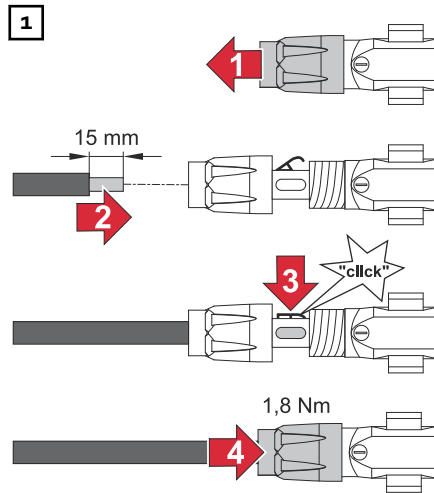

Connecting PV cables

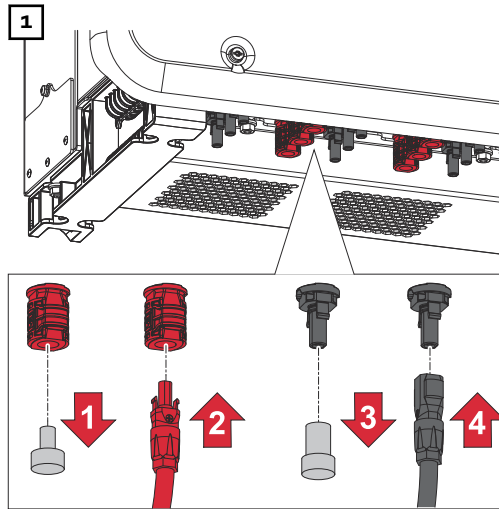

Connect the PV cables of the PV modules as labeled.

Unused plugs on the inverter must be closed using the cover caps supplied with the inverter.

Establishing equipotential bonding

Establishing equipotential bonding

Depending on local installation regulations, it may be necessary to ground the device with a second ground connection. The threaded bolt on the underside of the device can be used for this purpose.

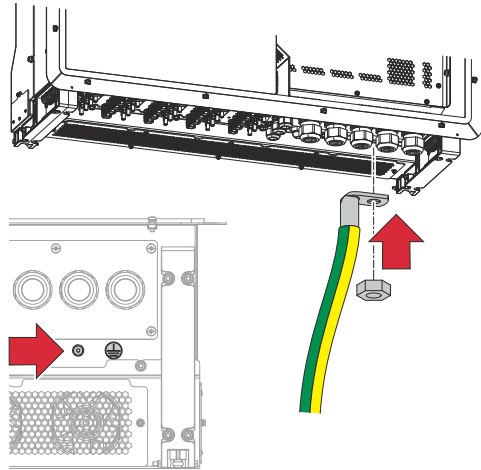

Connecting the data communication cables

Permitted cables for the data communication area

LAN connections

Fronius recommends using at least CAT 5 STP (shielded twisted pair) cables and a maximum distance of 100 m.

Multiple inverters in a network

The network cabling of the inverters can have a star or linear configuration. Ring connection is not permitted. Note the maximum lengths and cable requirements.

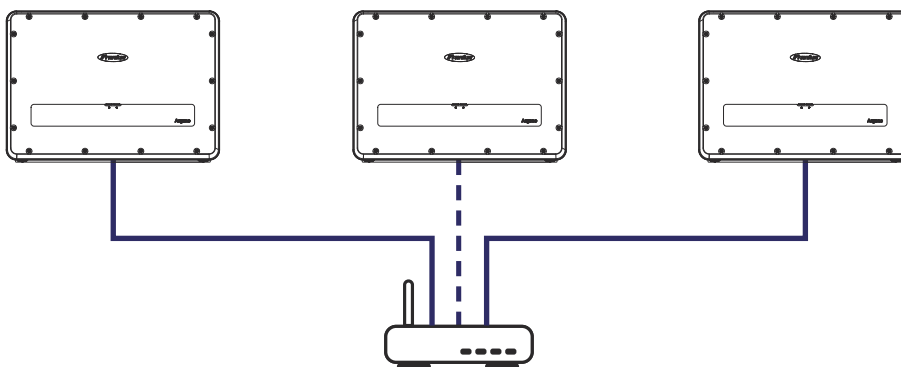

Network setup with star configuration

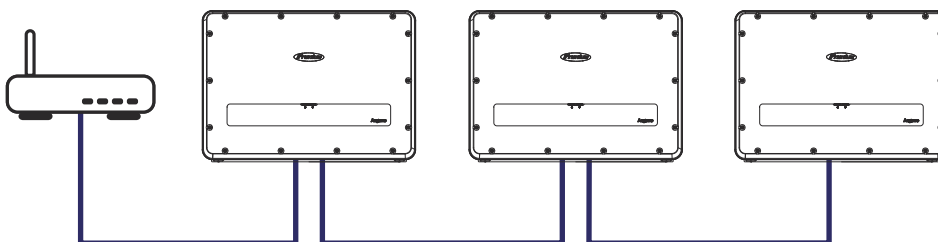

Network setup with linear configuration

Connecting the LAN cables

IMPORTANT! If data communication cables are wired into the inverter, observe the following points:

- Depending on the number and cross-section of the wired data communication cables, remove the corresponding blanking plugs from the sealing insert and insert the data communication cables.
- Make sure that you insert the corresponding blanking plugs into any free openings on the sealing insert.

Note! Safety class IP 66 cannot be ensured if blanking plugs are missing or incorrectly inserted.

1

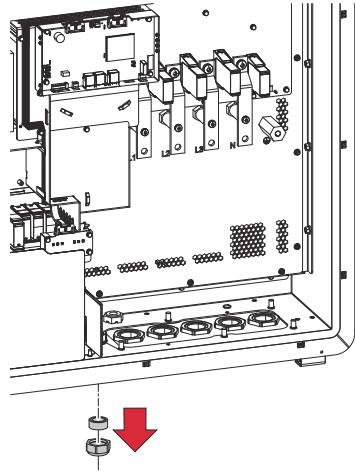

Remove the cap nut on the strain-relief device and press the sealing ring out from the inside of the device using the blanking plugs.

2

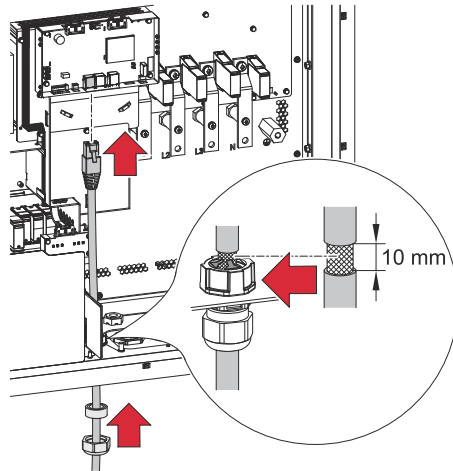

First, guide the data cables through the cap nut of the strain-relief device and then through the housing opening.

In the area of the shield support of the EMC cable gland, strip the lead by 10 mm up to the shield. The cable shield must touch the shield support of the EMC cable gland.

3

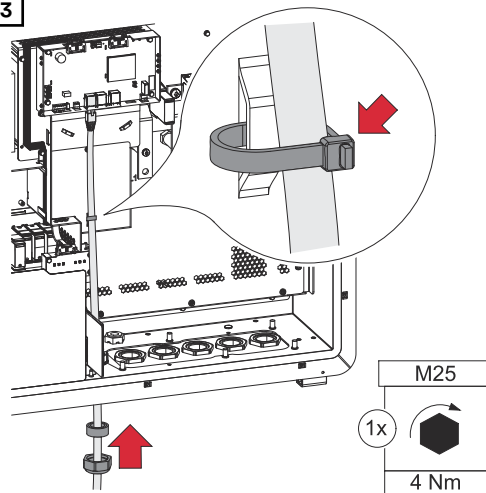

Connect the data cables to the data communication area and fasten the cap nut with min. 2.5-max. 4 Nm.

Connecting the ERR alarm relay

In addition to the option of connecting an audible or visible warning signal, external grid protection devices can also be controlled here.

Maximum contact rating	
DC	30 V/1 A
AC	250 V/1 A

Maximum contact rating

The contact is designed as a normally open contact.

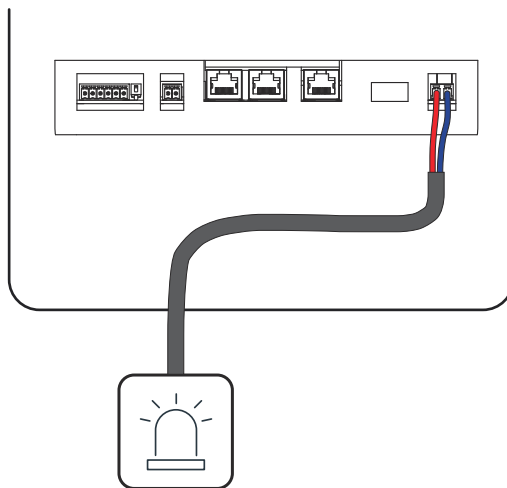

Connecting INV OFF

A separate power supply is needed when using a third-party device. An active-low signal is required to switch off the power supply.

One or more inverters can be connected.

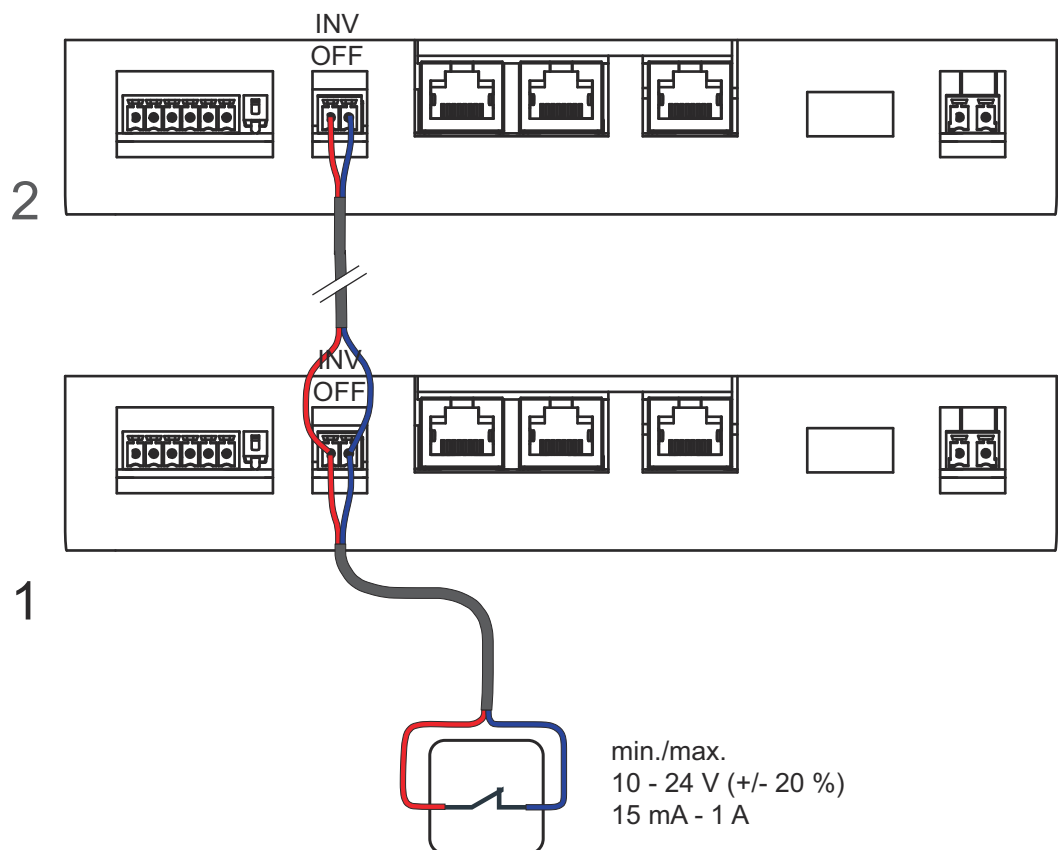

First startup

Closing and switching on the inverter

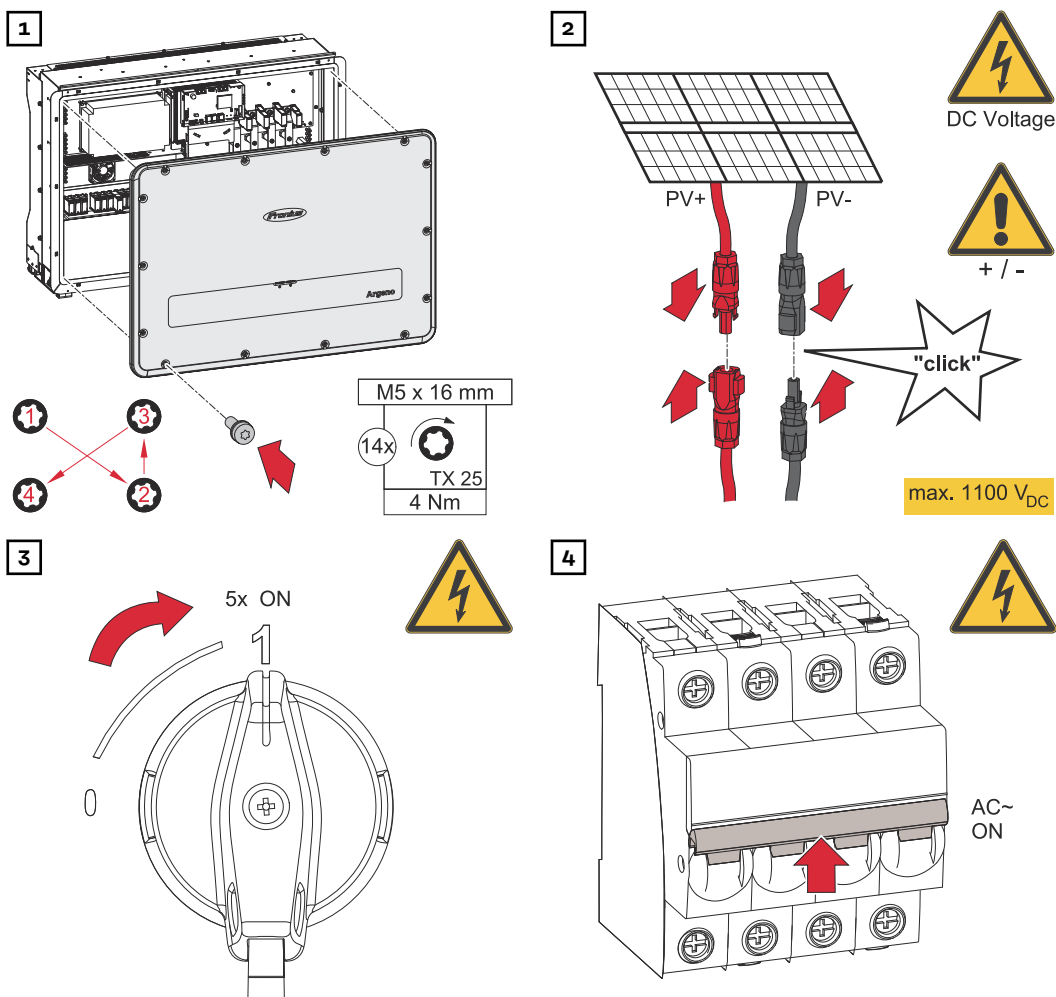

WARNING!

Housing components may become hot during operation.

Risk of burns due to hot housing components.

► Only touch the housing cover during operation.

Attaching safety stickers (France)



ATTENTION
Présence de deux sources de tension
- Réseau de distribution
- Panneaux photovoltaïques



Isoler les deux sources avant toute intervention

When connecting to the low-voltage grid in France, a safety sticker must be attached as per directive UTE C15-712-1. This sticker states that both voltage sources must be isolated in all cases before every intervention in the device.

- 1** Affix the supplied safety stickers on the outside of the device in a clearly visible location.

Establishing a local LAN connection

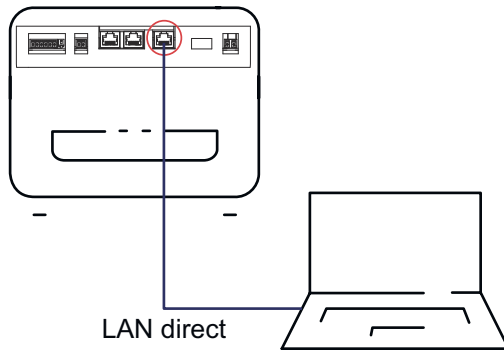

Application: The planned network infrastructure is not available yet. A DC power supply to the inverter is sufficient for commissioning.

You will need a laptop with a LAN interface and a LAN cable.

- 1 Connect the LAN cable to the laptop and inverter (direct LAN connection).
- 2 Enter the IP address **http://169.254.1.1** in the browser's address line and confirm.
 - ✓ *The installation wizard is displayed.*
- 3 Follow the installation wizard's instructions in the individual sections and connect the installation.

Establishing a LAN connection via a network

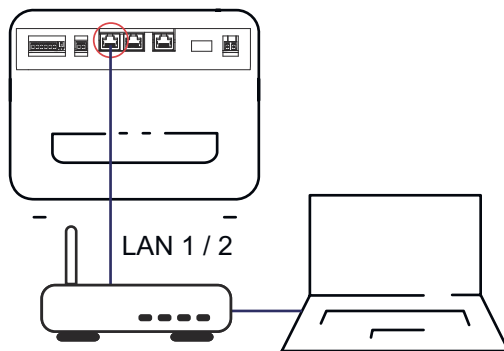

Application: The network infrastructure is available and the inverter needs to be integrated in this infrastructure. A DC power supply to the inverter is sufficient for commissioning.

The configuration may require IT work in the external network so a device IP can be assigned to the inverter.

- 1 Use a LAN cable (LAN1 or LAN2 connection) to connect the inverter to the existing network.
 - ✓ *A device IP address is automatically assigned to the inverter. This can either be requested from the network administrator or found using an IP scanner tool.*
- 2 Open a browser on the PC.
- 3 Enter the device IP address (**http://<device-IP-address>**) or host name (**http://xyz**). The host name is the serial number of the device.
 - ✓ *The device configuration page is displayed.*

Starting the inverter for the first time

The device must be mounted and all electrical installation work completed when starting for the first time. The PV modules must supply a higher voltage than the start-up input voltage.

Once authorization is complete and the "Configuration" option has been selected in the main menu, you will be taken straight to the installation wizard (provided that the device is still as delivered and has yet to be commissioned).

The installation wizard can also be accessed again later on to make subsequent changes to the original configuration.

The installation includes a number of steps as described below:

- Language selection
- Country configuration
- Power limitation (if necessary)
- Network parameters
- Localization
- Modbus
- Optional parameters
- Finalization

Access via Modbus

The device supports Modbus/TCP and the standard SunSpec models. Write access can be disabled if security is an issue.

- 1** Activate **Configuration > Communication > Ethernet > Modbus TCP / UDP > Modbus TCP/UDP Activation** on the user interface of the inverter.
 - 2** Enable **Modbus TCP/UDP Write access** if necessary.
 - 3** Set the **Port** for Modbus access [default: **502**].
- ✓ *Modbus access is enabled.*

De-energizing the inverter and switching it back on

**De-energizing
the inverter and
switching it back
on**

1

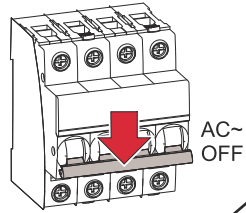

1. Turn off the automatic circuit breaker.
2. Turn the DC disconnectors to the "Off" switch setting.

To start up the inverter again, follow the steps listed above in reverse order.

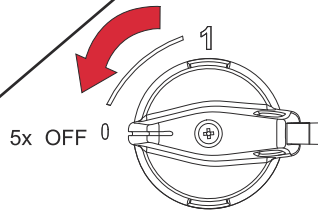

User interface of the inverter

General

Overview



Monitor

Displays a current overview of the most important measurement data.



Yield

Displays the system yield as a diagram.



Configuration

Displays the various configuration options for the system.



Service

Displays various service settings for the system.



Info

Displays the following information:

- Device information
- Software version
- Network information



Installer

??



Disconnect Grid

??

Update

The device carries out regular checks for relevant updates at: ...fronius.com

For information on changes and improvements included in the updates (change logs) and information on pending updates, please see: ...fronius.com

Network

The device carries out regular checks for relevant updates at: ...fronius.com.
For information on changes and improvements included in the updates (change logs) and information on pending updates, please see: ...fronius.com

Server addresses for data transfer

If a firewall is used for outgoing connections, the below protocols, server addresses, and ports must be allowed for successful data transfer, see:

https://www.fronius.com/~/downloads/Solar%20Energy/Firmware/SE_FW_Changelog_Firewall_Rules_EN.pdf

When using FRITZ!Box products, Internet access must be configured without any restrictions or limitations. The DHCP Lease Time (validity) must not be set to 0 (=infinite).

Monitoring

Monitoring

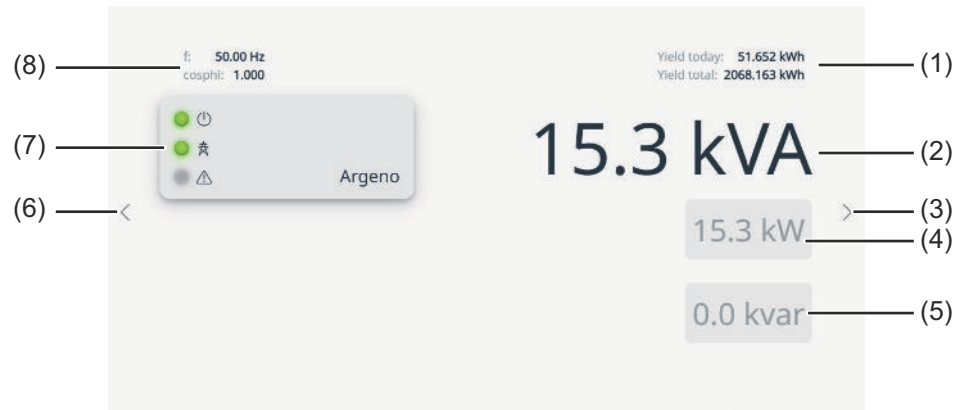

- (1) Yield today and Yield total
- (2) Current power in kVA
- (3) Button for scrolling to the next page
- (4) Current power in kW
- (5) Current reactive power in kvar
- (6) Button for scrolling to the previous page
- (7) Inverter status indicators
- (8) Reactive power factor

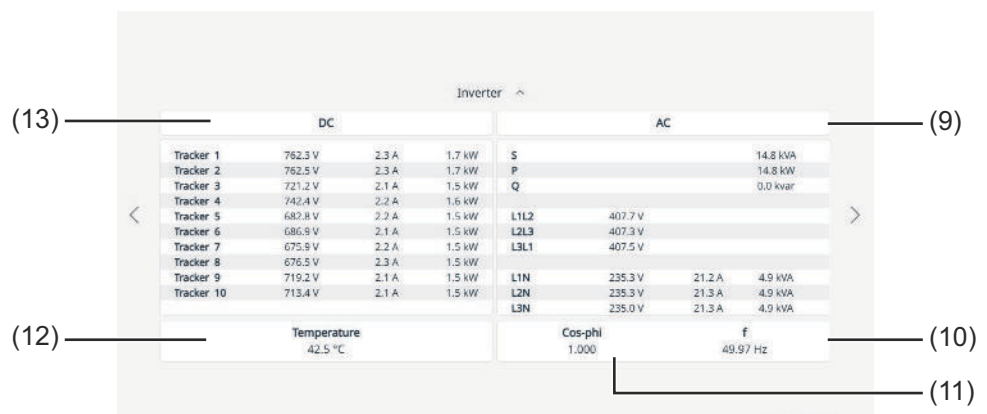

- (9) AC values
- (10) Frequency
- (11) Cos-phi
- (12) Temperature
- (13) DC values

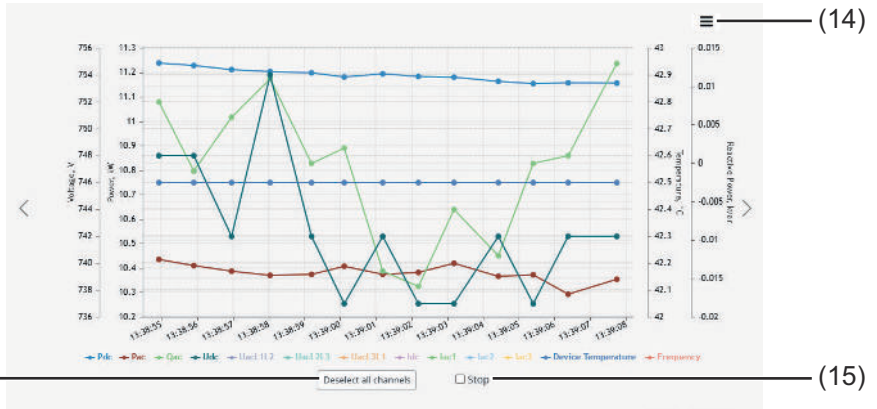

(14) Export function

(15) Stop

(16) Deselect all channels

Yield

Configuring via a web interface

Display	Setting	Description
Day view		Displays recorded operating data as a diagram. 1 Select a day. ✓ <i>The web interface displays the selected data.</i>
Week view		Displays recorded operating data as a diagram. 1 Select a week. ✓ <i>The web interface displays the selected data.</i>
Month view		Displays recorded operating data as a diagram. 1 Select a month. ✓ <i>The web interface displays the selected data.</i>
All view		Shows total yield so far.
Export / Print	Print PNG PDF JPEG SVG GIF	Option to print or save the diagram. 1 Select output format. 2 Specify the save location.

Configuration

General

Password protecting special network parameters

1. Once the password is enabled, it also applies for external change requests (e.g., via Modbus or other external interfaces).
2. You will be asked for the password if you want to change a protected network parameter. After entering the password, protection for all protected network parameters (including the password protection setting) is disabled for 15 minutes. Protection is automatically re-enabled once this time has elapsed.
3. If you disable a protected parameter group, you will need to enter the password first if this has not already been entered during the session.
4. Once a set of configuration parameters has been exported, the password becomes part of this configuration.
5. If the configuration is imported into a different device, the other device has the same protection status. If the other device was previously protected and the password for the new configuration is different, the new configuration is rejected.

Localization

Input screens for basic settings

Display	Setting	Description
Language	Castellano Dansk Deutsch English Français Italiano Magyar	1 Select the desired user interface language.
Date		1 Select the current date.
Time		1 Select the current time.
Timezone		1 Select the time zone.
Temperature unit	Celsius Fahrenheit	1 Specify the temperature unit.
Device name		1 Enter the device name.

AC Settings

Input screens for network parameters

Display	Setting	Description
Country / Grid This option influences the country-specific operating settings of the device.		
Country		1 Select the country.
Nominal grid voltage	[V]	1 Optional: Specify the nominal grid voltage.
Nominal grid frequency	[Hz]	If the grid frequency deviates from the nominal grid frequency by more than 9.5 Hz, the device switches off.
		1 Optional: Specify the nominal grid frequency.
		2 Confirm the action field.

Display	Setting	Description
Trip Settings		
Enable shutdown according to generic parameters, frequency, or voltage.		
- Generic parameters Option to activate standard protective shutdown		
Trip with intentional delay	Check to enable	1 Enable delayed trip if necessary. 2 Confirm the action field.
- Frequency Option to monitor frequency tripping		
Trip underfrequency monitoring	Status	1 Enable if necessary.
Number of trip underfrequency levels	1-5	1 Specify the number of protection levels.
Trip underfrequency level 1	45-65 [Hz]	If the grid frequency is in the deactivation range for the duration of the deactivation time, the function is disabled.
Trip underfrequency time level 1	0-100,000 [ms]	
Trip underfrequency level 2-5	42.5-65 [Hz]	1 Define the range and trip time.
Trip underfrequency time level 2-5	0-100,000 [ms]	
Trip overfrequency monitoring	Status	1 Enable if necessary.
Number of trip overfrequency levels	1-5	1 Specify the number of protection levels.
Trip overfrequency level 1	45.0-66 [Hz]	If the grid frequency is in the deactivation range for the duration of the deactivation time, the function is disabled.
Trip overfrequency time level 1	0-1,000,000 [ms]	
Trip overfrequency level 2-5	45.0-66 [Hz]	1 Define the range and trip time. 2 Confirm the action field.
Trip overfrequency time level 2-5	0-1,000,000 [ms]	
- Voltage Option to monitor voltage tripping		
Trip undervoltage monitoring	Status	1 Enable if necessary.
Number of trip undervoltage levels	1-5	1 Specify the number of protection levels.
Trip undervoltage level 1	10-100 [% U _{nom}]	1 Define the range and trip time.
Trip undervoltage time level 1	0-180,000 [ms]	
Trip undervoltage level 2-5	10-100 [% U _{nom}]	
Trip undervoltage time level 2-5	0-180,000 [ms]	

Display	Setting	Description
Trip overvoltage monitoring	Status	1 Enable if necessary.
Number of trip overvoltage levels	1-5	1 Specify the number of protection levels.
Trip overvoltage level 1	100-125 [% U _{nom}]	1 Define the range and trip time. 2 Confirm the action field.
Trip overvoltage time level 1	0-180,000 [ms]	
Trip overvoltage level 2-5	100-125 [% U _{nom}]	
Trip overvoltage time level 2-5	0-180,000 [ms]	
- 10 minutes average Monitor a deviation in the average voltage over 10 minutes.		
10 minutes average	100-125 [% U _{nom}]	1 Enable if necessary.
Island Detection If islanding is detected, utilities require that the device be shut down; see Enhanced island detection on page 100.		
Mode	Off ROCOF ROCOF enhanced Frequency shift	Function is set to active at the factory and may only be disabled in the case of autonomous stand-alone operation (without grid). 1 Select the mode and note the menu items. 2 Enable optional password protection. 3 Confirm the action field.
Ramp Rate Limitation Option to limit power when rated/maximum power increases and decreases.		
Operation mode	On Off	1 Select the mode and note the menu items.
Increasing & Decreasing gradient	1-65,534 [%/min]	This percentage value refers to the rated/maximum power. 1 Select the mode and note the menu items. 2 Confirm the action field.
Connection Conditions Set the connection conditions precisely according to your network conditions.		
Min. conn. voltage after grid mon.	10-110 [% U _{nom}]	1 Set connection voltage range after grid monitoring.
Max. conn. voltage after grid mon.	90-125 [% U _{nom}]	
Min. conn. frequency after grid mon.	45-65 [Hz]	1 Set connection frequency range after grid monitoring.
Max. conn. frequency after grid mon.	45-65 [Hz]	
Min. conn. voltage after grid failure	10-110 [% U _{nom}]	1 Set connection voltage range after grid failure.
Max. conn. voltage after grid failure	90-125 [% U _{nom}]	

Display	Setting	Description
Min. conn. frequency after grid failure	45-65 [Hz]	<ol style="list-style-type: none"> 1 Set connection frequency range after grid monitoring.
Max. conn. frequency after grid failure	45-65 [Hz]	
Monitoring time PV voltage	1,000-1,800,000 [ms]	<ol style="list-style-type: none"> 1 Set time for monitoring the mains voltage and PV voltage.
Waiting time after grid failure	1,000-1,800,000 [ms]	<ol style="list-style-type: none"> 1 Set waiting time after grid failure. 2 Enable optional password protection. 3 Confirm the action field.
Active Power Control Active Power Control can be used to permanently set the output power of the device to a smaller value than the maximum output power; see also Effective power control on page 84.		
- Internal Option to set an internal power limit in accordance with the requirements of the utility to limit the maximum connected load of the system at the grid connection point.		
Power limitation	Check to enable	<ol style="list-style-type: none"> 1 Specify the activation status.
Maximum apparent power Slim	10,000-125,000 [VA]	Maximum apparent power limits the internal power of the device. <ol style="list-style-type: none"> 1 Enter value or set using the slider.
Maximum active power Plim	1.0-100.0 [% Slim]	Maximum active power (effective power) limits the internal power of the device. <ol style="list-style-type: none"> 1 Enter value or set using the slider.
- External Parameters configured here are used as defaults if they are not sent via the communication interface or if communication for the configured fallback time fails.		
Power limitation	Check to enable	<ol style="list-style-type: none"> 1 Specify the activation status.
AC fallback active power	0-100 [% Plim]	Specifies the standard power in the event of a communication failure. If no effective power command is received within the fallback time configured below, the inverter sets the power to the configured fallback power. <ol style="list-style-type: none"> 1 Set the fallback power.
Fallback time	0-43,200 [s]	IMPORTANT! After the configured fallback time, external (RS485 or Modbus) defaults for cos phi, Q, and P are reset to the respective fallback value configured (Cos-phi constant, Q constant, or fallback power). If the fallback time is set to 0s, external defaults for cos phi, Q, and P are not reset (inverter continues operating with the last set value received). <ol style="list-style-type: none"> 1 Enter value or set using the slider.
Output gradient limitation increase & decrease	1-65,534 [% Slim / min]	<ol style="list-style-type: none"> 1 Set maximum change in the effective power if power increases. 2 Set maximum change in the effective power if power decreases.

Display	Setting	Description
Settling time	200-60,000 [ms] / 1,000 [ms]	1 Set the settling time. 2 Confirm the action field.
- P(f) Enable frequency-dependent power reduction in the P(f) menu.		
Operation mode	Off Mode 1 Mode 2 Mode 3	1 Specify the operation mode. Mode 1 = Hysteresis active - Limit ; Mode 2 = Hysteresis inactive - Limit; Mode 3 = Hysteresis inactive - Set
Power reference at underfrequency	Actual power Nominal power	1 Specify control method for underfrequency. 2 Specify control method for overfrequency.
Power reference at overfrequency	Actual power Nominal power	
Dynamic gradient mode	On Off	"Gradient at under/overfrequency (feed-in)" is not displayed. 1 Enable dynamic gradient.
Gradient at underfrequency (feed-in)	0-200 (%/Hz)	1 Specify gradient for feed-in at overfrequency. 2 Specify gradient for feed-in at underfrequency.
Gradient at overfrequency (feed-in)	0-200 (%/Hz)	
Activation threshold at underfrequency	40-50 [Hz]	1 Set frequency thresholds for the activation of the power limitation in case of undervoltage.
Activation threshold at overfrequency	50-60 [Hz]	2 Set frequency thresholds for the activation of the power limitation in case of overvoltage.
Activation delay	0-5,000 [ms]	1 Set the regulation delay.
Output gradient limitation increase & decrease	1-65,534 [% Slim / min]	1 Specify the output gradient limitation increase and decrease.
Settling time	200-2,000 [ms]	1 Set the settling time mode. 2 Confirm the action field.
Deact. lim. time after fault	0-1,000 [s]	The change in the effective power is limited to the configured gradient for the specified time after a fault. Only evaluated in modes 2 and 3.
Deact. grad. incr. & decr. after fault	0-65,534 [% / min]	Limits the change in effective power after a fault. Only evaluated in modes 2 and 3.
- P(U) Enable voltage-dependent power reduction in the P(U) menu.		
Operation mode	Off On	1 Enable the control process. Off: Deactivates dynamic grid support using dynamic reactive current. Dynamic grid support remains active on account of interference immunity.
Reference power	Actual power Nominal power	1 Select the power-dependent control method.

Display	Setting	Description
Evaluated voltage	Maximum phase voltage Positive phase sequence voltage	Specifies which voltage is evaluated in a three-phase system. 1 Select the power-dependent control method.
Hysteresis mode	Off On	Hysteresis mode affects the shutdown response of P(U). 1 Enable the mode.
Deactivation gradient	0-65,534 [% / min]	1 Set gradients for the voltage limitation.
Deactivation time	0-60,000,000 [ms]	1 Specify the time for voltage reduction.
Output gradient limitation increase & decrease	1-65,534 [% Slim / min]	1 Specify the output gradient limitation increase and decrease.
Settling time	500-120,000 [ms]	1 Set the settling time.
Active curve	Curve 1-5	Up to five characteristics can be configured independently and one of them can be enabled for regulation each time. 1 Select active curve.
Number of nodes	2-5	1 Specify the number of nodes.
Power	0.0-100.0 [% Pref]	1 Specify power for 1st, 5th ... node as a percentage of the maximum power.
Voltage	80.0-125.0 [% Unom]	2 Specify voltage for 1st, 5th ... node as a percentage of the maximum voltage. 3 Confirm the action field.
- Power Rampup Power rampup is used to ramp up the power gradually; see Soft start up / power ramp-up limiting on page 98.		
Power rampup gradient	1-3,000 [% / min]	1 Set increase.
Rampup on every connect	Check to enable	1 Enable option.
Rampup on first connect		2 Confirm the action field.
Rampup after grid failure		
Reactive Power Control Enable the reactive power process in the mode menu; see Reactive power control on page 75		
- Mode		
Mode	Cos-phi constant Q constant Cos-phi(P/Plim) Q(U) Q(P)	1 Select a control process. 2 Confirm the action field.
- Cos-phi constant		
Cos-phi constant	0.3-1	1 Determine the specified power factor.

Display	Setting	Description
Power gradient increase & decrease	1-65,534 [% Slim / min]	<ol style="list-style-type: none"> 1 Set the maximum change in the reactive power %Slim/min in the event of a change to overexcited mode. 2 Set the maximum change in the reactive power %Slim/min in the event of a change to underexcited mode.
Settling time	1,000-120,000 [ms]	<ol style="list-style-type: none"> 1 Set the settling time in the event of an abrupt change in the reactive power set value (e.g., caused by a voltage jump). 2 Confirm the action field.
- Q constant		
Priority mode	Q-Priority P-Priority	<ol style="list-style-type: none"> 1 Set priority.
Q constant	0-100 [% Slim] underexcited overexcited	<ol style="list-style-type: none"> 1 Set reactive power Q to a fixed value. 2 Select the type of phase shift. <p>Underexcited corresponds to an inductive load, overexcited to a capacitive load.</p>
Output gradient limitation increase & decrease	1-65,534 [% Slim / min]	<ol style="list-style-type: none"> 1 Set the maximum change in the reactive power in the event of a change to overexcited mode. 2 Set the maximum change in the reactive power in the event of a change to underexcited mode.
Settling time	1,000-120,000 [ms]	<ol style="list-style-type: none"> 1 Set the settling time in the event of an abrupt change in the reactive power set value (e.g., caused by a voltage jump). 2 Confirm the action field.
- Cos-phi(P)		
Lock-In voltage	10-126.6 [% Un-om]	<ol style="list-style-type: none"> 1 Set the voltage above which control is activated.
Lock-Out voltage	10-126.6 [% Un-om]	<ol style="list-style-type: none"> 1 Set the voltage below which control is deactivated.
Power gradient increase & decrease	1-65,534 [% S _{lim} /min]	<ol style="list-style-type: none"> 1 Set the maximum change in the reactive power %S_{lim}/min in the event of a change to overexcited mode. 2 Set the maximum change in the reactive power %S_{lim}/min in the event of a change to underexcited mode.
Settling time	1,000-120,000 [ms]	<ol style="list-style-type: none"> 1 Set the settling time in the event of an abrupt change in the reactive power set value.
Number of nodes	2-10	<p>The maximum number of configurable nodes depends on the selected grid type.</p> <ol style="list-style-type: none"> 1 Specify the number of nodes.
Node 1-node 10 Power Curve	0-100% [% Slim]	<p>For the first node, the power must be 0%, for the last node the power must be 100%. The power values of the nodes must increase continuously.</p> <ol style="list-style-type: none"> 1 Specify the power factor for 1st, 10th ... node as a percentage of the maximum power.

Display	Setting	Description
Cos phi Curve	0.3-1 ind./cap.	1 Specify cos j of the node.
Excitation Curve	overexcited underexcited	Overexcited corresponds to a capacitive load, underexcited to an inductive load. 1 If a reactive power not equal to 1 is selected: Select the type of phase shift. 2 Confirm the action field.
- Q(P)		
Power gradient increase & decrease	1-65,534 [% S_{lim}/min]	1 Specify the power gradient increase and decrease.
Settling time	200-60,000 [ms]	1 Set the settling time in the event of an abrupt change in the rated power set value.
Number of nodes	2-10	The maximum number of configurable nodes depends on the selected grid type. 1 Specify the number of nodes.
Node 1-node 10 Power Curve	0-100% [% S_{lim}]	For the first node, the power must be 0%, for the last node the power must be 100%. The power values of the nodes must increase continuously. 1 Specify the power factor for 1st, 10th ... node as a percentage of the maximum power.
Q Curve	0.3-1 ind./cap.	1 Specify cos φ of the node.
Excitation Curve	overexcited underexcited	1 If a reactive power not equal to 1 is selected: Select the type of phase shift.
- Q(U)		
Lock-In power	0-100 [% S_{lim}]	1 Set the effective power as a % of the rated power above which control is activated.
Lock-Out power	0-100 [% S_{lim}]	1 Set the effective power as a % of the rated power below which control is deactivated.
Lock-In time	0-60,000 [ms]	1 Set the length of time that the effective power must remain above the lock-in/lock-out power before control is activated.
Lock-Out time	0-60,000 [ms]	1 Set the length of time that the effective power must remain above the lock-in/lock-out power before control is activated.
Dead time	0-10,000 [ms]	1 Set the intentional delay for the start of the Q(U) function.
Output gradient limitation increase & decrease	1-65,534 [% S_{lim}/min]	1 Set the maximum change in the reactive power in the event of a change to overexcited mode. 2 Set the maximum change in the reactive power in the event of a change to underexcited mode.
Settling time	1,000-120,000 [ms]	1 Set the response speed of the control.
Min. cos-phi Q1 - min. cos-phi Q4	0-1	1 Enter the minimum cos φ factor for quadrants 1 and 4.
Voltage dead band	0-5 [% U_{ref}]	1 Set voltage dead band in %.
Q(U) offset (temporary) U offset Q offset	-100-100 [% S_{lim}] -100-100 [% S_{lim}]	1 Set intended Q or U Offset for the function.

Display	Setting	Description
Q minimum	0-100 [% Slim] underexcited overexcited	<ol style="list-style-type: none"> 1 Set reactive power Q to a min. value. 2 Select the type of phase shift. <p>Underexcited corresponds to an inductive load, overexcited to a capacitive load.</p>
Q maximum	0-100 [% Slim] underexcited overexcited	<ol style="list-style-type: none"> 1 Set reactive power Q to a max. value. 2 Select the type of phase shift. <p>Underexcited corresponds to an inductive load, overexcited to a capacitive load.</p>
US, US: Autonomous adjustment Vref		<ol style="list-style-type: none"> 1 When activating autonomous adjustment, the reference voltage of the reactive power function is adjusted to the measured voltage with the help of a PT-1 filter. This causes dynamic shifting of the Q(U) characteristic.
US, UD: Time constant Vref adjustment	300-5,000 [s]	<ol style="list-style-type: none"> 1 Set the time constant for adjusting the dynamic reference voltage.
Priority mode	Q-Priority P-Priority	<p>With P priority, the reactive power adjustment range is limited subject to the effective power that is currently available and being fed in.</p> <ol style="list-style-type: none"> 1 Set priority for reactive power – Q or effective power – P.
Active curve	1-4 / Curve 1 TMP / Curve 2 / Curve 3 / Curve 4	
Number of nodes	2-10	<p>The maximum number of configurable nodes depends on the selected grid type.</p> <ol style="list-style-type: none"> 1 Specify the number of nodes.
1. node ... 10. node	Power Voltage Excitation 0-100 [% S _{lim}]	<ol style="list-style-type: none"> 1 Set the reactive power of the node as a percentage of the maximum power
	Power Voltage Excitation 0-125 [% S _{lim}]	<p>The voltage values of the nodes must increase continuously. At voltages below the first node and voltages above the last node, the reactive power value of the first or last node is used.</p> <ol style="list-style-type: none"> 1 Enter the voltage of the node in volts.
	Power Voltage Excitation overexcited un- derexcited	<p>Overexcited corresponds to a capacitive load, underexcited to an inductive load.</p> <ol style="list-style-type: none"> 1 Select the type of phase shift.
<p>Dynamic Grid Support The device supports dynamic grid stabilization (fault ride through); see Dynamic grid support on page 92.</p>		

Display	Setting	Description
Operation mode	On Off	<p>1 Select a control process.</p> <p>On: Activates dynamic grid support using dynamic reactive current.</p> <p>Off: Deactivates dynamic grid support using dynamic reactive current. Dynamic grid support remains active on account of interference immunity.</p>
Setting	Manual Pre-defined zero current	<p>1 Select a control process.</p>
Reference voltage	80.0-110.0 [% Unom]	<p>1 Set reference voltage for active control process.</p>
Zero current activation / deactivation undervoltage	0-80 [% Unom]	<p>If one or more phase-phase or phase-neutral conductor voltages fall below or exceed the configured threshold, the inverter switches to zero current mode. The total current is regulated to virtually zero.</p>
Zero current activation / deactivation overvoltage	110-141.8 [% Unom]	
<p>Overvoltage protection Shutdown is carried out within a grid cycle.</p>		
Transient overvoltage protection	114.8-127.5 [% Unom]	<p>1 Set the transient overvoltage protection.</p> <p>2 Confirm the action field.</p>
<p>External Grid Protection Option to detect the external grid protection devices.</p>		
External grid protection	No device INV OFF Third-party device	<p>1 Select device.</p>

DC Settings Input screens for DC source (module array/battery).

Display	Setting	Description
<p>DC starting voltage The device starts feeding in as soon as this voltage is present.</p>		
DC starting voltage		<p>1 Set the start-up input voltage.</p> <p>2 Confirm the action field.</p>
<p>Insulation resistance</p>		
Insulation resistance	36-1,000 [kOhm]	<p>1 Set the threshold value from which the insulation monitoring reports an error.</p> <p>2 Confirm the action field.</p>
<p>DC Configuration The correct DC configuration must be set prior to connecting the individual DC strings. Connections to the inputs used may only be made either separately or in parallel. Mixed operation can damage the device.</p>		

Display	Setting	Description
DC configuration	All inputs separate All inputs parallel	<p>Observe the recommended default configuration!</p> <ol style="list-style-type: none"> 1 Select "All inputs separate" if strings are connected individually. 2 Optional: Select "All inputs parallel" if strings are connected in parallel. 3 Confirm the action field.
<p>Global MPPT</p> <p>To determine the global MPP, first MPP trackers (1/3/5/7/9) and then MPP trackers (2/4/6/8/10) are considered. During this time, which lasts approx. 30 minutes in each case, the system deviates from the MPP and causes a reduction in yield. A reduction in the interval time therefore further reduces the yield. If a parallel connection is made to two DC inputs of the device in each case, only one cycle is performed to determine the global MPP. If a global MPP is found, the MPP search algorithm is active again and tracks the changes to make the maximum possible power of the PV modules available.</p>		
Global MPPT enable	On Off	<ol style="list-style-type: none"> 1 Enable mode for active management to all MPPT trackers.
Time interval	5-120 min	<ol style="list-style-type: none"> 1 Set the time interval.

Communication Input screens for configuring the interfaces.

Display	Setting	Description
<p>Ethernet</p> <p>Option to parameterize the Ethernet interface.</p>		
<p>- IP Settings</p> <p>Option to parameterize network access.</p>		
DHCP	Check to enable	<p>On: If a DHCP server is available, the IP address, subnet mask, gateway, and DNS server are automatically obtained from this server and the mentioned menu entries filled out.</p> <p>Off: Settings are made manually.</p> <ol style="list-style-type: none"> 1 Enable or disable DHCP.
IP address		<ol style="list-style-type: none"> 1 Assign an IPv4 address that is unique in the network.
Subnet mask		<ol style="list-style-type: none"> 1 Assign subnet mask.
Default gateway		<ol style="list-style-type: none"> 1 Enter the IPv4 address of the gateway.
Primary & Secondary DNS (optional)		<ol style="list-style-type: none"> 1 Enter the IPv4 address of the DNS server. 2 Confirm the action field.
<p>- Modbus TCP / UDP</p> <p>Option to set the Modbus port.</p>		
Modbus TCP/UDP Activation	Check to enable	<ol style="list-style-type: none"> 1 Allow Modbus TCP/UDP write access.

Display	Setting	Description
Modbus TCP/UDP Write access	Check to enable	Enabling write access makes it possible to set system-critical parameters via Modbus TCP. Are you sure you want to allow write access? <ol style="list-style-type: none"> 1 Allow Modbus TCP write access. 2 Confirm the action field.
Modbus TCP/UDP Port		<ol style="list-style-type: none"> 1 Set network port.
<p>- MQTT The MQTT protocol is used to implement the advanced functions between the segment controller and the inverter (in particular, firmware updates, distribution of device configurations, etc.).</p>		
Broker auto discovery	Check to enable	
Broker IP		The default setting ensures successful communication with the segment controller.
Broker port		<ol style="list-style-type: none"> 1 Displays the IP address transmitted by the segment controller. 2 Confirm the action field.
Solar.web		
In this menu, you can agree to the technically necessary data processing or reject it.		

Features / Functions Input screens for extended device functions.

Display	Setting	Description
AFPE (arc-fault protection equipment)		
ARC Manual Restart		
Constant voltage control Option to disable MPP seek mode so the device operates with a constant DC voltage. Energy recovery to the PV generator can occur if constant voltage control is enabled and the system is running in "Q on Demand" mode. Please note the instructions and approval of the module manufacturer.		
Constant voltage mode	Off On	<ol style="list-style-type: none"> 1 Enable or disable constant voltage regulator.
Constant voltage		<ol style="list-style-type: none"> 1 Set value for constant voltage regulator. 2 Confirm the action field.
SPD monitoring Option to check the available surge protection device with corresponding status codes		
SPD monitoring AC SPD monitoring DC	Check to enable	<ol style="list-style-type: none"> 1 Enable surge protection device. 2 Confirm the action field.
Q on Demand Only enable this function if this is expressly permitted by the utility. Further conditions: <ul style="list-style-type: none"> - No PID solution connected to the device. - Constant voltage regulator in the device is disabled. 		

Display	Setting	Description
Night Shutdown	Check to enable	<p>The reactive power settings currently specified are used. Power-dependent functions are not used.</p> <p>If an AC disconnect occurs overnight, the function will only be available the following day.</p> <ol style="list-style-type: none"> "Q on Demand" function is enabled by disabling the night shutdown. Transfer the function to the memory. Note information in the notification window and use OK button to enable the function.
Compliant with type B RCD		
Enable this function when using a type B RCD		
Compliant with type B RCD	Check to enable	<ol style="list-style-type: none"> Enable connected type B RCD. Confirm the action field.
Relay		
Relay	Positive logic Negative logic Inactive Active	<ol style="list-style-type: none"> Select the type of logic. Select the form of activity. Confirm the action field.

Service / Maintenance Option to perform updates, access service and parameter data, and grant remote access.

Display	Setting	Description
Firmware Update		
Option to update the device. Parameter data is not overwritten during firmware updates.		
Instant Update		<ol style="list-style-type: none"> Select the firmware update file using the Browse... button and confirm Start the firmware update using the Upload button. The AC and DC supply to the inverter must be ensured throughout the entire update process. A loss of supply may damage the device. Continue with the update?
Export Service Package		
Option to send an error log.		
Export Service Package		<ol style="list-style-type: none"> Press the export button and send the file to Fronius.
Service Log		
Shows all logged installations. You should also use the "Service" and "Installer" interface to manually add all maintenance tasks.		
Service Log		<ol style="list-style-type: none"> Enter additional service tasks (exception: "user" interface) Export service logs if necessary.
Logging Management		
Input screens for log and service data and defaults.		

Display	Setting	Description
- Settings Set the interface for data logging and the basic counter.		
User logging interval	1 5 10 15 [minutes]	Setting and time until memory is overwritten: 1 min-5 days; 5 min-4.5 years; 10 min-9 years; 15 min-14 years. 1 Specify time span between two log data captures.
Service logging interval	1-120 [sec]	Setting and time until memory is overwritten: 1 sec-9 days; 10 sec-92.5 days; 120 sec-1,110 days 1 Specify time span between two log data captures.
DC-DSP logging interval	1-120 [sec]	Setting and time until memory is overwritten: 1 sec-9 days; 10 sec-92.5 days; 120 sec-1,110 days 1 Specify time span between two log data captures.
ARC-DSP logging interval	1-120 [sec]	Setting and time until memory is overwritten: 1 sec-9 days; 10 sec-92.5 days; 120 sec-1,110 days 1 Specify time span between two log data captures.
- Analyze Log Data All measurement data can be transferred to a USB thumb drive by making individual or multiple selections.		
User logs	cosPhi fac (Hz) lac1 (A) lac2 (A) lac3 (A) idc (A) Qac (var)	1 Select a date in the calendar. 2 Select measurement data from the drop-down field. 3 Update the measurement data. 4 Transfer the selected measurement data to the storage device or transfer the data selectively.
Parameter Management Option to reset set values as well as to import and export specific parameters.		
Factory Settings		1 Compare all parameters / country-specific parameters / network-specific parameters with basic setting value. 2 If necessary, reset parameters using the Restore button.
Export Configuration		1 Parameters to export for device independent settings / Export all settings. 2 Create the selection of parameters for export in a file or the system manager.
Import Configuration		1 Select the parameter file using the Browse... button. 2 Import the parameters using the Upload button.
Installation Wizard		
Installation Wizard		After the installation is complete, the following text appears: Installation wizard was completed
Network Statistics Displays the data packages that have been transmitted and received.		
Network Statistics		1 Reload network statistics.
History		

Display	Setting	Description
Shows all actions carried out in the system and on the web interface.		
Account Management		
Account Management		<p>After starting for the first time, the default password must be changed.</p> <ol style="list-style-type: none"> 1 Enter a user name. 2 Enter a user-defined password.
Reboot Device		
Transfer safety-relevant parameters to a medium.		
Reboot Device		<ol style="list-style-type: none"> 1 Restart the device if necessary.

Advanced settings

Reactive power control

Reactive power control

Reactive power can be used in electrical energy supply networks to bolster the level of voltage. As such, feed-in inverters can contribute to static voltage stability. Reactive power brings about a voltage drop at the inductive and capacitive components of the equipment which can either bolster or reduce the level of voltage depending on what is indicated. If the generating system draws inductive reactive power while effective power is being fed in, part of the voltage swing caused by the effective power feed can be compensated for by drawing reactive power.

The reactive power mode and the respective control process are specified by the utility. If no control process has been specified, the system should be operated with a fixed reactive power specification of 0%.

Operating power range depending on mains voltage

The device can be operated within the respective fixed voltage range stated. The maximum apparent power in the event of undervoltage depends on the mains voltage due to the maximum continuous current, as shown in the table below. The following figures show the reactive power operating range as a function of the effective power and the apparent power operating range as a function of the mains voltage for various devices.

Maximum continuous apparent power as a function of the mains voltage:

Maximum apparent power [p.u.]	Argeno 125 voltage with U_N 380 V
1.0	≥ 397
0.95	377
0.90	357
0.85	337

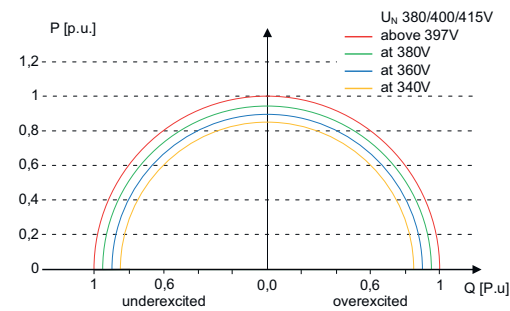

P-Q operating range

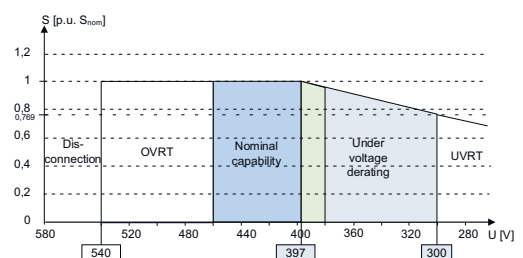

Apparent power subject to mains voltage

Dynamics and accuracy

For all of the control methods, the specified set value at the inverter's connection terminals is adjusted using a stationary deviation of the reactive power of maximum 2% S_N . This maximum deviation always relates to the value specified for the reactive power. If the $\cos \varphi$ power factor is specified in the control method, the deviation relates to the reactive power value resulting from the current power level.

The transient response of the control methods is determined by a PT-1 filter. The settling time is 5 tau, which corresponds to achieving approx. 99% of the final

value of a PT-1 filter. Depending on the control method selected, there are also other parameters that determine dynamic behavior.

Reactive power functions

The following functions for controlling reactive power are implemented:

- cos constant φ
- Q constant
- cos j (P)
- Q(P) 10 nodes
- Q(U) 10 nodes

Reactive power is prioritized by default for all methods but can be disabled. The priority can be selected when using the Q constant and Q(U) mode. The maximum possible effective power that can be fed in is reduced in line with the P-Q operating range when the maximum useful power is reached.

Model	Parameter	Scale factor	R/R W	Range	Description
126.	ModEna	ModEna	RW	0 / 1	The reactive power process selected in the device can only be enabled/disabled indirectly via SunSpec.

cos constant φ

In cos φ constant mode, the specified power factor is set permanently by the inverter. The reactive power level is set in line with $Q = P * \tan \varphi$ as a function of the power so the specified power factor is continually maintained. If the setting value changes, the new value is adopted by way of a filter in a muted manner. The settling time can be parameterized and is 1 second (corresponds to 5 tau, while the ideal time according to SunSpec is 3 tau) with the transient response of a PT-1 filter with a time constant of $\tau = 200$ ms. The specified power factor can be configured on the display or via communication using the RS485 protocol and MODBUS/SunSpec.

If the applicable grid code calls for the φ to respond to the set value with a defined gradient or a defined settling time that is shorter than the configured $\tau = 200$ ms, this gradient or settling time must be implemented in the system controls

Model	Parameter	Scale factor	R/R W	Range	Description
123.	OutPFSet cos-phi constant	OutPF- Set_SF	RW	1-0.3 [°]	Set power factor to a specific value
123.	OutPF- Set_RmpTms Power gradient increase & Power gradient decrease		R	1-65,524 [% Slim / min]	Specifies the dynamic behavior on changing the cos φ power factor. The power factor is changed with the specified gradient. Note: The gradient is overlaid with the settling time.
123.	OutPF- Set_WinTms Settling time	VArPct_SF	RW	1,000-120,000 [ms]	Set the settling time in the event of an abrupt change in the reactive power set value (e.g., caused by a voltage jump).

Model	Parameter	Scale factor	R/R W	Range	Description
123.	OutPF- Set_RvrtTms Timeout		RW	0-1,000 [s]	Specifies the time after which the inverter reverts to the previously valid reactive power process if it does not receive a new power factor specification. If the timeout is set to 0 seconds, the sent power factor specification is permanently maintained, even in the event of a communication failure. Note: If the device is restarted, the timeout is reset to the configured fall-back time.

Q constant

In Q constant mode, the specified reactive power value is set permanently by the inverter. If the specification is changed, the new value is adopted by way of a filter in a muted manner. The settling time and gradient limit can be configured via the web interface. The settling time is 1 second and follows the transient response of a PT-1 filter with a time constant of $\tau = 200$ ms. The specified reactive power can be configured on the display or via communication using the RS485 protocol and MODBUS/SunSpec.

If the applicable grid code calls for the reactive power to be adjusted to the set value with a defined gradient or a defined settling time that is shorter than the configured $\tau = 200$ ms, this gradient or settling time must be implemented in the system controls.

Model	Parameter	Scale factor	R/R W	Range	Description
123.	VArWMaxPct Q constant	VArPct_SF	RW	0-100 [%Pmax]	The reactive power set value can be set as a function of the configured maximum effective power.
123.	VArPct_RvrtTms Timeout		RW	0-1,000 [s]	Specifies the time after which the inverter reverts to the previously valid reactive power process if it does not receive a new reactive power specification. If the timeout is set to 0 seconds, the sent reactive power specification is permanently maintained, even in the event of a communication failure. Note: If the device is restarted, the timeout is reset to the default value.

Model	Parameter	Scale factor	R/R W	Range	Description
123.	VArPct_RmpTms Output gradient limitation in- crease & Output gradient limita- tion decrease		R	1-65,524 [% Slim / min]	Specifies the dynamic be- havior on changing the re- active power value power factor. The reactive power is changed with the spe- cified gradient. Note: The gradient is overlaid with the settling time.
123.	VArPct_RmpTms Settling time		RW	1,000-12 0,000 [ms]	Specifies the dynamic be- havior on changing the ef- fective power set value. The effective power is changed according to a PT-1 characteristic with a settling time of 5 tau. NOTE: The settling time is overlaid with the increas- ing and decreasing gradi- ent.

cos φ(P)

In the cos φ (P) operating mode, the cos φ set value and the reactive power set value derived from this are calculated continuously as a function of the actual power level. This function ensures that grid support is provided by the reactive power when a significant voltage boost is anticipated due to a high feed-in level. A characteristic is specified which can be used to configure up to 10 nodes, i.e., value pairs for effective power and φ. The effective power is entered as a percentage in relation to the maximum apparent power Slim. Other parameters can be used to limit functionality and to limit activation to certain voltage ranges.

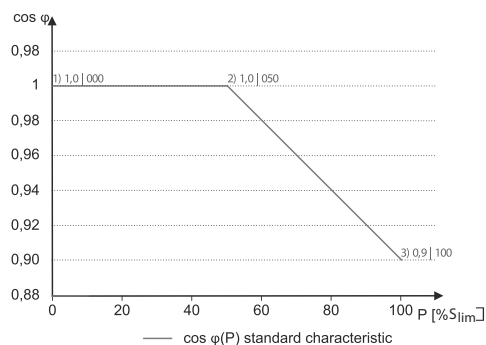

cos φ (P) standard characteristic with three nodes

Q(U) 10 nodes

In Q(U) mode, the reactive power set value is calculated continuously as a function of the mains voltage. This function ensures that grid support is provided by the reactive power as soon as the voltage actually deviates from the target voltage. In this case, a characteristic is specified which can be used to configure up to 10 nodes consisting of value pairs for voltage and reactive power. Other parameters allow you to limit functionality and to limit activation to certain power levels as well as to parameterize the transient response. The displacement voltage of the neutral point is used to calculate the reactive power set value for three-phase devices.

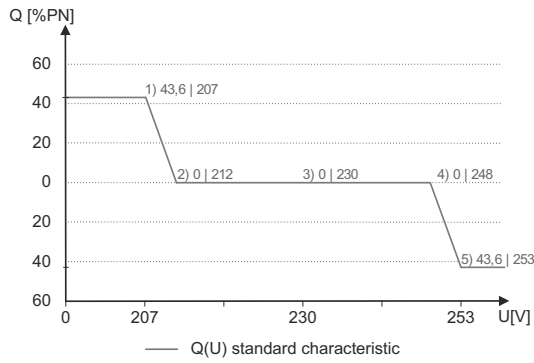

Q(U) standard characteristic with five nodes

Q(P) 10 nodes

In Q(U) mode, the reactive power set value is calculated continuously as a function of the effective power. In this mode, a characteristic is specified which can be used to configure up to 10 nodes consisting of value pairs for power and reactive power. The function allows you to parameterize the transient response. The displacement power of the neutral point is used to calculate the reactive power set value for three-phase devices.

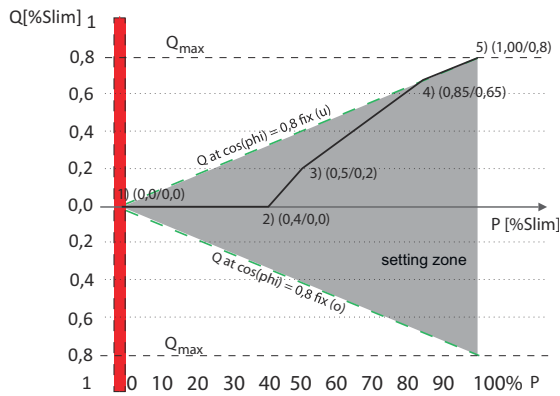

Q(P) standard characteristic with five nodes

Parameters for reactive power control

Display	Setting	Description
Mode	cos-phi constant Q constant Cos-phi(P/ P _{lim}) Q(U) Q(P)	Select active process for reactive power control and define the parameters in the respective process.
Cos-phi constant		
Cos-phi constant	0.3-1	Specified power factor
	overexcited under-excited	Reactive power mode: Underexcited corresponds to an inductive load, overexcited to a capacitive load.
Power gradient increase & decrease	1-65,534 [% S _{lim} /min]	Maximum change in the reactive power %S _{lim} /min when switching to overexcited mode. The gradient is overlaid with the settling time.

Display	Setting	Description
Settling time	1,000-120,000 [ms]	Specifies the dynamic behavior on changing the $\cos \varphi$ set value. In the event of a change in the reactive power, $\cos \varphi$ is changed according to a PT-1 characteristic with a settling time of 5 tau.
Q constant		
Q constant	0-100 [% Slim]	Set as a percentage of the maximum reactive power.
	overexcited under-excited	Reactive power mode: Underexcited corresponds to an inductive load, overexcited to a capacitive load.
Output gradient limitation increase & decrease	1-65,534 [% S_{lim}/min]	In addition to configuring the dynamic behavior using the settling time corresponding to a first-order filter, the reactive power setting can be determined by a maximum gradient, i.e., the maximum change in the reactive power per time period.
	increase decrease	Maximum change in the reactive power %Slim/min in the event of switching to overexcited mode. The gradient is overlaid with the settling time.
Settling time	1,000-120,000 [ms]	Specifies the dynamic behavior on changing the Q set value. In the event of a change in the reactive power or with lock-in or lock-out, Q is changed according to a PT-1 characteristic with a settling time of 5 tau.
Cos-phi(P)		
Lock-In voltage	10-126.6 [% Unom]	The control is activated above this voltage.
Lock-Out voltage	10-126.6 [% Unom]	The control is deactivated below this voltage.
Power gradient increase & decrease	1-65,534 [% S_{lim}/min]	Maximum change in the reactive power % S_{lim}/min when switching to overexcited mode. The gradient is overlaid with the settling time.
Settling time	1,000-120,000 [ms]	Specifies the dynamic behavior on changing the $\cos \varphi$ set value. In the event of a change in the effective power or with lock-in or lock-out, $\cos \varphi$ is changed according to a PT-1 characteristic with a settling time of 5 tau.
Number of nodes	2-10	Specify the number of nodes for the $\varphi / (p/pn)$ characteristic.
1. node ... 10. node	0 V-max. voltage continuous operation	Power of the node as a percentage of the maximum power. For the first node, the power must be 0%, for the last node the power must be 100%. The power values of the nodes must increase continuously.
	1-0.3	Reactive power of the node as a percentage of the maximum power.
	overexcited under-excited	Reactive power mode: Underexcited corresponds to an inductive load, overexcited to a capacitive load.
Q(P) 10 nodes		

Display	Setting	Description
Power gradient increase & decrease	1-65,534 [% S _{lim} /min]	The rate of change of the output is limited by the configured value in the event of an increase in the output power. The rate of change of the output is limited to the configured value in the event of a decrease in the output power. The gradient is overlaid with the settling time.
Settling time	200-60,000 [ms]	Sets the dynamic behavior on changing the Q set value. In the event of a change in the effective power, the Q set value is changed according to a PT-1 characteristic with a settling time of 5 tau.
Number of nodes	2-10	Specify the number of nodes for the Q(P) characteristic.
1. node ... 10. node	0 V-max. voltage continuous operation	Power of the node as a percentage of the maximum power. For the first node, the power must be 0%, for the last node the power must be 100%. The power values of the nodes must increase continuously.
	1-0.3	Reactive power of the node as a percentage of the maximum power.
	overexcited underexcited	Reactive power mode: Underexcited corresponds to an inductive load, overexcited to a capacitive load.
Q(U) 10 nodes		
Lock-In power	0-100 [% S _{lim}]	Effective power threshold above which the function is activated.
Lock-Out power	0-100 [% S _n]	Effective power threshold below which the function is activated.
Lock-In time	0-60,000 [ms]	Length of time for which the effective power must remain below the lock-in power before control is deactivated.
Lock-Out time	0-60,000 [ms]	Length of time for which the effective power must remain below the lock-out power before control is deactivated.
Dead time	0-10,000 [ms]	If the voltage switches from a characteristic section with Q=0 to a characteristic section with Q ≠ 0 during active control, the reactive power setting is delayed by the set dead time. Once the dead time has expired, the control circuit is no longer subject to a delay and the set settling time determines the transient response.
Output gradient limitation increase & decrease	1-65,534 [% S _{lim} /min] increase decrease	In addition to configuring the dynamic behavior using the settling time corresponding to a first-order filter, the reactive power setting can be determined by a maximum gradient, i.e., the maximum change in the reactive power per time period. Maximum change in the reactive power %S _{lim} /min when switching to overexcited mode. The gradient is overlaid with the settling time.

Display	Setting	Description
Settling time	1,000-120,000 [ms]	Settling time in the event of an abrupt change in the reactive power set value (e.g., caused by a voltage jump). The transient response corresponds to a first-order filter (PT-1) with a settling time = 5 tau. The settling time is overlaid with the increasing and decreasing gradient.
Min. cos-phi Q1 - min. cos-phi Q4	0-1	In the event of a significant voltage deviation, the maximum reactive power range can be limited by a minimum cos φ in order to prevent excessive feed-in of reactive power and, as a result, a significant reduction in the maximum effective power that can be fed in
Q1		Minimum φ in overexcited operating mode (feed-in).
Q4		Minimum φ in underexcited operating mode (feed-in).
Q2		Minimum φ in overexcited operating mode (charging).
Q3		Minimum φ in underexcited operating mode (charging).
Voltage dead band	0-5 [% Uref]	The control is activated above this voltage.
Q(U) offset (temporary) U offset Q offset	-100-100 [% Slim] -100-100 [% Slim]	Effective power threshold above which the function is activated.
Q minimum	0-100 [% Slim] underexcited overexcited	Set reactive power Q to a minimum value. Select the type of phase shift. Underexcited corresponds to an inductive load, overexcited to a capacitive load.
Q maximum	0-100 [% Slim] underexcited overexcited	Set reactive power Q to a maximum value. Select the type of phase shift. Underexcited corresponds to inductive load, overexcited to a capacitive load.
US, US: Autonomous adjustment Vref		The autonomous adjustment of the reference voltage enables a dynamic reactive power function. The reference voltage of the Q(U) characteristic is thus dynamically adjusted to the mains voltage via a PT-1 filter.
US, UD: Time constant Vref adjustment	300-5,000 [s]	The time constant defines the control speed by which the reference voltage of the Q(U) characteristic is adjusted to the mains voltage.
Priority mode	Q-Priority P-Priority	P priority can be selected as an alternative to the default Q priority setting. With P priority, the reactive power adjustment range is limited subject to the apparent power limitation of the inverter and the active (effective) power that is currently available and being fed in.
Active curve	1-4 / Curve 1 TMP / Curve 2 / Curve 3 / Curve 4	Up to four characteristics can be configured independently and one of them can be activated for regulation each time.
Number of nodes	2-10	Specify the number of nodes for the Q(U) characteristic.

Display	Setting	Description
1. node ... 10. node	Power Voltage Excitation 0-100 [% S_{lim}]	Power of the node as a percentage of the maximum power. For the first node, the power must be 0%, for the last node the power must be 100%. The power values of the nodes must increase continuously.
	Power Voltage Excitation 0-125 [% S_{lim}]	Voltage of the node in volts. The voltage values of the nodes must increase continuously. At voltages below the first node and voltages above the last node, the reactive power value of the first or last node is used.
	Power Voltage Excitation overexcited underexcited	Reactive power mode: Underexcited corresponds to an inductive load, overexcited to a capacitive load.

Effective power control

Dynamics/accuracy

In all of the control methods described below the specified set value at the inverter's terminals is adjusted using a stationary deviation of the effective power of maximum 2% S_N .

The transient response of the control methods is determined by a PT-1 filter. The settling time is 5 tau, which corresponds to achieving approx. 99% of the final value with a PT-1 filter. Depending on the control method selected, there are also other parameters that specify dynamic behavior.

Methods for effective power regulation

Methods for regulating the effective power of feed-in inverters may be necessary for local management of load flows, for voltage stability in the distribution network, and for ensuring the stability of the interconnected grid.

The device makes use of the following functions in order to regulate the effective power. These functions are described below:

- P set value (MPPT (communication))
- P limit (communication)
- P(U) (characteristic)
- P(f) (characteristic)

P set value

On all inverters, the function "P set value" is integrated in the MPP tracking of the inverter. The P set value is continually recalculated based on the MPP tracking algorithm.

Model 704 (DER AC controls) thus also corresponds to the current market specifications.

P limit

The "P limit" function is available for limiting the maximum power of feeding in. If necessary, this can be used to reduce the maximum possible feed-in of an inverter, e.g., for managing bottlenecks for the operator of the distribution grid.

P limit is only available via the MODBUS/SunSpec inverter model 123 Immediate Controls and via RS485 communication.

When a set value is received for P limit, the output power of the inverter is limited to the specified power value. If the limit value is changed, the new value is adopted by way of a filter and a gradient limit. The actual power may be below the specified limit value because the available power (PV) and the set power value (storage) may be below the specified limit value. Depending on the inverter series, the settling time and gradient limit may be adjustable.

Model	Parameter	Scale factor	R/R W	Range	Description
123	WMaxLimPct Power limitation	WMaxLimPc t_SF	RW	0-100 [%]	Set power limitation to a specific percentage value.

Model	Parameter	Scale factor	R/R W	Range	Description
123	WMaxLimPct_Rvr tTms Timeout		RW	0-1,000 [s]	Specifies the time after which the inverter increases the power limitation if it does not receive a new one. If the timeout is set to 0 seconds, the power limitation that is sent is permanently maintained, even in the event of a communication failure. Note: If the device is restarted, the timeout is reset to the default value.
123	WMaxLimPct_Rm pTms Output gradient limitation in- crease		RW	1-65,534 [% S _{lim} / min]	Specifies the dynamic behavior on changing the effective power set value. The effective power is changed with the specified gradient. The gradient is overlaid with the settling time.

If the applicable grid connection guidelines call for the effective power to be adjusted to the set value with a defined gradient or a defined settling time, the device can be configured in such a way that this gradient is adhered to. The gradient can also be implemented on the system controller. This second solution is to be used for all other inverters.

Voltage-dependent power reduction P(U)

If the voltage increases too sharply in the upstream distribution network and not enough reactive power can be absorbed, it may be necessary to reduce the effective power. In this case, P(U) control is available for making optimum use of the grid.

P(U) control reduces the effective power that is fed in as a function of the mains voltage using a prescribed characteristic as a basis. P(U) control is implemented as an absolute power limit. The actual power of the inverter may vary freely below this limit due to a possible fluctuation in the available power or the set value, but at no time increases above the absolute power limit.

Configuration examples:

- **Without hysteresis:** The function is activated as soon as the voltage exceeds the value of data point 1 (dp1). The power limit follows a straight line between dp1 and dp2. The function is deactivated as soon as the voltage falls below dp1.

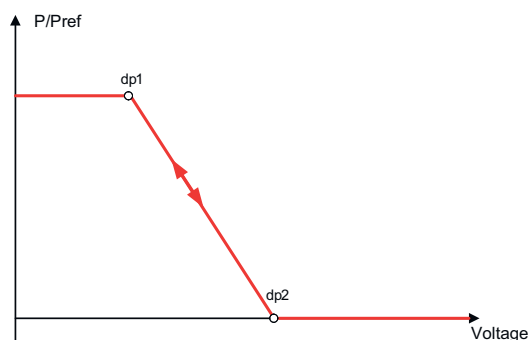

Characteristic example without hysteresis

- **With hysteresis:** The function is activated as soon as the voltage exceeds the value of data point 2 (dp2). In this case, the power limit remains at 100% if the voltage exceeds dp1. The power limit follows a straight line between dp2 and dp3. Because of the activated hysteresis, the power limit is not increased when the voltage drops. The function is deactivated as soon as the voltage drops below dp1.

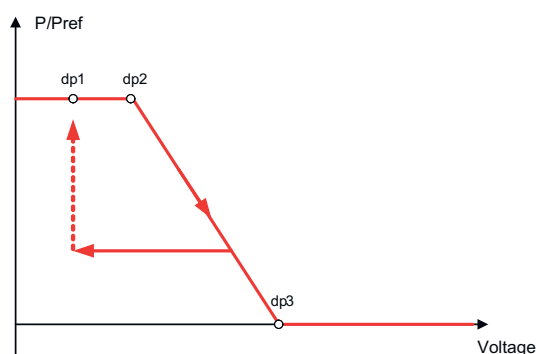

Characteristic example with hysteresis and a deactivation threshold below the activation threshold

Display	Setting	Description
Operation mode	Off On	Enable the control process. Off: Deactivates dynamic grid support using dynamic reactive current. Dynamic grid support remains active on account of interference immunity.
Reference power	Actual power Nominal power	Specifies the power reference for the characteristic. In this case, 100% corresponds to the rated power or the actual power at the time the function was activated, the time when the voltage passes the configured node.
Evaluated voltage	Maximum phase voltage Positive phase sequence voltage	Select the voltage to be rated. Specifies which voltage is evaluated in a three-phase system.
Hysteresis mode	Off On	Off: In non-hysteresis mode, the effective power is increased immediately if the voltage drops. On: In hysteresis mode, the power is not increased if the voltage drops.

Display	Setting	Description
Deactivation gradient	0-65,534 [% / min]	If the available power is above the actual output at the time of deactivation, the power increase back to the maximum power is limited. The limitation is implemented by an absolute power limitation that increases with a continuous gradient up to the maximum power. The actual power of the inverter may vary freely below this limit due to a possible fluctuation in the available power or the set value, but at no time increases above the absolute power limit.
Deactivation time	0-60,000,000 [ms]	Only evaluated when hysteresis mode is enabled: Monitoring time during which the voltage must remain below the lowest configured node before the function is disabled.
Output gradient limitation increase & decrease	1-65,534 [% / min]	Specifies the dynamic response on changing the effective power for power increase. If the voltage changes, the effective power is changed with the specified gradient. The gradient is overlaid with the settling time. Specifies the dynamic response on changing the effective power for power decrease. If the voltage changes, the effective power is changed with the specified gradient. The gradient is overlaid with the settling time.
Settling time	1,000-120,000 [ms]	Specifies the dynamic behavior on changing the effective power set value. In the event of a change in the voltage, the effective power is changed according to a PT-1 characteristic with a settling time of 5 tau. The settling time is overlaid with the increasing and decreasing gradient.
Active curve	1-5	Select active curve. Up to five characteristics can be configured independently and one of them can be enabled for regulation each time.
Number of nodes	2-5	Up to five nodes can be configured. The power value of the first and last value pair is also used as the maximum or minimum effective power value, which is valid beyond the limits of the characteristic.
Power	0.0-100.0 [% P _{ref}]	
Voltage	80.0-126.0 [% U _{nom}]	

P(f)

Adjusting the effective power P(f) in the event of overfrequency

Feed-in inverters must assist with frequency stability in the interconnected grid. If the grid frequency leaves the normal tolerance range (e.g., ± 200 MHz), the grid is in a critical state. In the event of overfrequency, there is a generation surplus; in the event of underfrequency, there is a generation deficit. Photovoltaic systems must adapt their power of feeding in relative to the frequency deviation. In the event of overfrequency, the power adjustment is determined by a maximum feed-in limit. The actual power of the inverter may vary freely below this limit due

to a possible fluctuation in the available power or the set value, but at no time increases above the absolute power limit.

$$P_{max-limit} = P_M + \Delta P$$

Equation 1

$$\Delta P = g \cdot P_{ref} \cdot (f_1 - f)$$

Equation 2

Equation 1 defines the maximum limit with ΔP as per equation 2, P_M the actual power at the time of activation, and P_{ref} the reference power. P_{ref} is defined as P_M , the actual power at the time of activation. f is the actual frequency and f_1 is the specified activation threshold.

$$\Delta P = \frac{1}{s} \times \frac{(f_1 - f)}{f_n} \times P_{ref}$$

Equation 3

$$g = \frac{1}{s \cdot f_n}$$

Equation 4

In some standards, the power adjustment is specified by a drop (s) instead of a gradient (g), as shown in equation 3. The drop s can be transformed into a gradient g in accordance with equation 4.

The frequency f remains above the activation threshold f_1 during an overfrequency event. Consequently, the expression $(f_1 - f)$ is negative and ΔP corresponds to a reduction in the power of feeding in.

The measurement accuracy of the frequency is greater than 10 MHz.

The specific mode of operation of the function is specified by the utility, the relevant standards, or the grid connection guidelines. The option to configure the function makes it possible to satisfy a wide variety of standards and guidelines. Certain configuration options are not available in some country settings because the relevant standards or grid connection guidelines prohibit adjustments.

Adjusting the effective power $P(f)$ in the event of underfrequency

Some grid connection rules also require that the effective power $P(f)$ be adjusted in the event of underfrequency. Because photovoltaic systems are typically operated in the maximum power point, a power reserve is not available to increase the power in the event of underfrequency.

However, if the system is curtailed based on the market regulations, the effective power can be increased up to the available power. Because the inverter is unable to distinguish set values for the P constant between the utility's obligatory bottleneck management and market regulations, this must be implemented as part of the site-specific infrastructure for controlling the system.

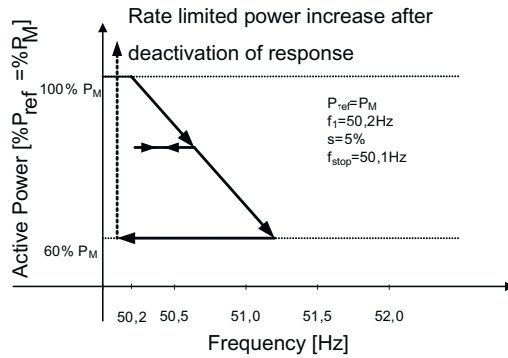

Example behavior with hysteresis

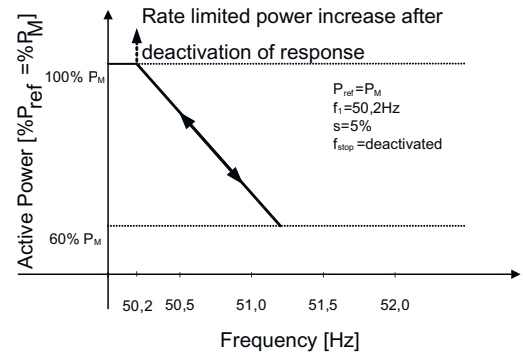

Example behavior without hysteresis

Parameters for P(f)

Display	Setting	Description
Operation mode	Off Mode 1 Mode 2 Mode 3	<p>Activate or deactivate function.</p> <p>Mode 1: Hysteresis active – Limit.</p> <p>Mode 2: Hysteresis inactive – Limit.</p> <p>In mode 1 and 2, the power is adjusted above or below the characteristic (depending on overfrequency or underfrequency) using a Pset command. Plim can also limit the power if there is an active P(f) characteristic.</p> <p>Mode 3: Hysteresis inactive – Set.</p> <p>In mode 3, the pre-fault power is saved and the power matches this characteristic.</p>
Dynamic gradient mode	On Off	<p>Enable dynamic gradient.</p> <p>"Gradient at under/overfrequency (feed-in)" is not displayed.</p>
Maximum dynamic gradient frequency	50.22-70.5 [Hz]	<p>Dynamic gradient maximum frequency: If dynamic gradient mode is enabled, the gradient is calculated in order to guarantee a linear power adjustment and reach the maximum charging power if the frequency rises to the configured maximum frequency.</p> <p>Dynamic gradient minimum frequency: If dynamic gradient mode is enabled, the gradient is calculated in order to guarantee a linear power adjustment and reach the maximum power of feeding in if the frequency drops to the configured minimum frequency.</p>
Minimum dynamic gradient frequency	45-50 [Hz]	

Display	Setting	Description
Activation threshold at underfrequency	40-50 [Hz]	<p>Activation threshold (f1) underfrequency: Determines the frequency threshold for activating the function in case of underfrequency events. The effective power adjustment is activated if the frequency falls below the configured value and mode 1 or 2 is activated. In mode 2, the function is deactivated if the frequency rises above the configured value.</p> <p>Activation threshold (f1) overfrequency: Determines the frequency threshold for activating the function in case of overfrequency events. The effective power adjustment is activated if the frequency rises above the configured value and mode 1 or 2 is activated. In mode 2, the function is deactivated if the frequency falls below the configured value.</p>
Activation threshold at overfrequency	50-60 [Hz]	
Deact. range lower limit	40-50 [Hz]	<p>Only evaluated in mode 1. The function is deactivated if the frequency returns to the deactivation range and remains in this range for the duration the deactivation time.</p>
Deact. range upper limit	50-60 [Hz]	
Deactivation time	0-6,000,000 [ms]	<p>Only evaluated in mode 1. The function is deactivated if the frequency returns to the range between the minimum and maximum deactivation threshold and remains in this range for the duration of the deactivation time.</p>
Deact. lim. time after fault	0-1,000 [s]	<p>Only evaluated in mode 2 and 3. The change in the effective power is limited to the configured gradient for the specified time after a fault.</p>
Deact. grad. incr. & decr. after fault	0-65,534 [% / min]	<p>Specifies the dynamic response on changing the effective power for power increase and decrease. Any change in the effective power is limited to the configured value for the set period of time.</p>
Intentional delay	0-5,000 [ms]	<p>Activation of the function based on the activation threshold is delayed by the configured time.</p> <p>This function is regarded as critical for the stability of the transmission grid and is therefore prohibited by several national grid connection regulations.</p> <p>This function is stipulated as a requirement by some national grid connection directives in order to prevent any negative impact on island detection. However, P(f) has no negative impact on the enhanced island detection.</p>
Settling time	200-2,000 [ms]	<p>Specifies the dynamic behavior on changing the effective power limit. In the event of a change in the frequency, the effective power is changed according to a PT-1 characteristic with a settling time of 5 tau. The settling time is overlaid with the increasing and decreasing gradient.</p>

Display	Setting	Description
Output gradient limitation increase & decrease	0-65,534 [% / min]	<p>Specifies the dynamic response on changing the effective power for power increase and decrease. If the voltage changes, the effective power is changed with the specified gradient.</p> <p>The gradient is overlaid with the settling time.</p>
Deactivation gradient	0-65,534 [%S _{max} /min]	<p>If the available power is above the actual output at the time of deactivation, the power increase back to the maximum power is limited. The limitation is implemented by an absolute power limitation that increases with a continuous gradient up to the maximum power. The actual power of the inverter may vary freely below this limit due to a possible fluctuation in the available power or the set power value, but at no time increases above the absolute power limit.</p>

Dynamic grid support

Dynamic grid support (fault ride through)

The capacity of a generating system to remain immune to voltage dips and voltage spikes in the supply system is a key element in establishing a reliable energy supply. Interference immunity ensures that brief disruptions do not result in a loss of relevant generation capacity in a larger area of an interconnected grid. Grid support via fast feed-in of residual current also limits the spatial extent of the incident.

The device offers this characteristic with its dynamic grid support by way of interference immunity. The ability to remain on the grid is the relevant factor. The protection settings also determine the device's ability to remain on the grid or not. Protection settings prevail over the capacity of interference immunity.

Dynamic grid support by way of interference immunity

Interference immunity against undervoltage

Voltage dips above the limit curve (see figure below) can be overcome without the need for shutdown from the grid. The power of feeding in is constantly maintained within the limits of the maximum continuous current of the inverter. If a reduction in power occurs, the power is brought back up to the pre-fault level within 100 ms of the voltage returning.

The inverter can overcome voltage fluctuations provided that the voltage level does not stay above the continuous operating voltage range for more than 100 s and does not rise above the short-term maximum operating voltage range (up to 100 s). The specific values for each inverter can be found here.

The interface protection integrated in the inverter (voltage, frequency, anti-islanding) can be configured in a range that permits the above behavior. If, however, the setting of the interface protection limits the voltage/time characteristic, the interface protection triggers and interrupts the run-through as configured.

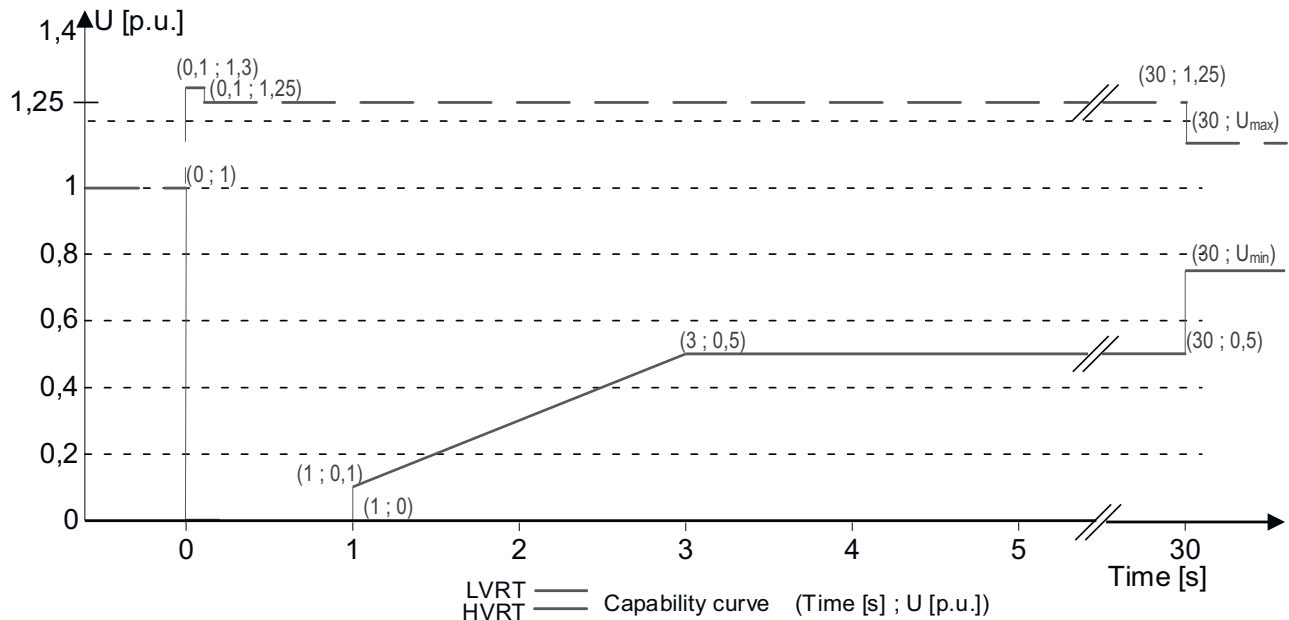

Interference immunity characteristic in relation to the nominal voltage $p(u)$

Dynamic grid support via fast feed-in of residual current

When dynamic grid support via fast feed-in of residual current is activated, residual current is fed-in in addition to the interference immunity properties against dips and spikes described above.

The inverter adapts its current feed-in as soon as a dip or spike event occurs in

order to bolster the mains voltage. The support takes place in the event of voltage dip with overexcited reactive current (corresponds to a capacitive load), and in the event of a voltage spike with underexcited reactive current (corresponds to an inductive load). In the reactive current priority mode, the active current is reduced to the extent necessary to comply with the limits of the maximum continuous current of the inverter.

A dip or spike is detected if either the normal operating voltage range setting is exceeded by at least one phase-phase or phase-neutral voltage, or if a jump in the positive or negative sequence component of the voltage greater than the deadband setting occurs. The magnitude of the voltage jump of the positive and negative phase-sequence system equates to the difference between the pre-fault voltage and the actual voltage based on the reference voltage. The pre-fault voltage is calculated as the mean value over 50 periods.

$$\Delta u = \frac{U - U_{50per}}{U_{ref}}$$

Formula 1

The reactive current is adapted using a response time of < 20 ms and a settling time of < 60 ms after the event has occurred. Responses to changes in the voltage during the event or to the voltage recovery at the end of the event take place with the same dynamic.

The formula for calculating the dynamic reactive current that is fed in for the positive and negative phase-sequence system is as follows:

$$I_b = \Delta u * k * I_N$$

Formula 2, depending on the nominal current I_N of the inverter

Δu For the positive and negative phase-sequence system, u equates to the difference between the pre-fault voltage and the current voltage in relation to the reference voltage. The pre-fault voltage is calculated as a 1-min mean value.

$$\Delta u = \frac{U - U_{1min}}{U_{ref}}$$

Formula 3

On account of the definition of a voltage jump in pre-norm EN50549-2 and in VDE-AR-N 4120 and VDE-AR-N 4110, it is typically the case that another voltage jump is detected when the event is at an end, when the fault is rectified, and when the voltage returns to a fault-free state. The result of this is that in an active operating mode, the dynamic grid support via a fast feed-in of residual current remains active even after the event has passed, and that reactive current is fed in according to formulas (2) and (3). Dynamic grid support using fast feed-in of residual current is then deactivated after a configured minimum support time, usually 5 s.

The inverter stops feeding in current if the zero current threshold is exceeded. If the inverter is feeding in reactive power before the fault, the reactive power is reset to the value before the fault Q with the settling time configured in the activated reactive power control mode after the fault.

$$I_b = (\Delta u_1 - t_b) * k * I_N$$

Formula 4

Parameters for FRT

Display	Setting	Description
FRT (Fault Ride Through)		The device supports dynamic grid stabilization (fault ride through).
Operation mode	On Off	<p>Setting: Manual All parameters can be configured independently.</p> <p>Setting: Predefined zero current Dynamic grid support active on account of interference immunity and zero current feed-in. During a voltage event, the current in the inverter is reduced to zero. All parameters are pre-configured, only the activation threshold for zero current has to be configured.</p>
Settings	Manual Predefined zero current	
Priority – limitation	Reactive current Active current priority	<p>Priority: Reactive current priority Dynamic grid support active on account of interference immunity and fast feed-in of residual current. The inverter feeds in additional reactive current according to formulas (2) and (4).</p> <p>Priority: Active current priority Dynamic grid support active on account of interference immunity and fast feed-in of residual current with active current priority. The inverter feeds in as much effective power as available. If, as a result of this, the maximum continuous current is not achieved, the inverter supplies additional reactive current according to formulas (2) or (4) up to the continuous current limitation.</p>
Zero current under-voltage threshold	0-184 V	If one or more phase-phase or phase-neutral conductor voltages exceed the configured threshold, the inverter switches to zero current mode. The total current is regulated to virtually zero.
Zero current over-voltage threshold	253-340 V	
Zero current under-voltage threshold	0-80 [% Unom]	If one or more phase-phase or phase-neutral conductor voltages exceed the configured threshold, the inverter switches to zero current mode. The total current is regulated to virtually zero.
Zero current over-voltage threshold	108-129 [% Unom]	
Reference voltage	80-110 [% Unom]	Nominal value of the phase-neutral conductor voltage used as a reference voltage for formulas (1) and (3). Adjustable in the range from level 1 under-voltage protection to level 1 overvoltage (surge) protection.
Constant k negative sequence dip and swell	k 0-10	Amplification factor for the negative phase-sequence system used in the calculation of the reactive current using formulas (2) and (4). Can be configured independently for drops and spikes.

Display	Setting	Description
Constant k positive sequence dip and swell	k 0-10	Amplification factor for the negative phase-sequence system used in the calculation of the reactive current using formulas (2) and (4). Can be configured independently for drops and spikes.
Dead band	2-120 [% Uref]	Dynamic grid support through fast feed-in of residual current is activated in the case of voltage events with a voltage change greater than the dead band.
Reference voltage	80-110.0 [% Unom]	Dynamic grid support via fast feed-in of residual current is activated in the case of voltage events with at least one phase-phase or phase-neutral conductor voltage outside the configured normal operating voltage range. Dynamic grid support via fast feed-in of residual current is deactivated when the voltage returns to the reference operating voltage range.
Minimum operating voltage activation	45-125.0 [% Unom]	
Maximum operating voltage activation	45-125.0 [% Unom]	
Minimum operating voltage deactivation	0-max [V]	Dynamic grid support via fast feed-in of residual current is deactivated if the voltage is within the configured deactivation range. This parameter is only available for the country-specific settings VDE 4105, CH 4105, and UD.
Maximum operating voltage deactivation	0-max [V]	
Dynamic reactive current only	Off On	<p>Standard: The reactive current according to formulas (2) and (4) is fed in as additional reactive current. This means that the sum of the pre-fault and additional reactive current is fed in.</p> <p>Dynamic only: The reactive current according to formulas (2) and (4) is fed in as absolute reactive current. This means that regardless of the reactive current before the voltage event, only the reactive current according to formulas (2) and (4) is fed in during the voltage event.</p>
Dead band mode	Mode 1 Mode 2	<p>Mode 1: When calculating the reactive current, the value of the dead band is not subtracted from the amount of voltage change. As such, formula (2) applies to overvoltage and undervoltage events.</p> <p>Mode 2: When calculating the reactive current, the value of the dead band is subtracted from the amount of voltage change. As such, formula (4) applies to overvoltage and undervoltage events:</p> $I_b = (\Delta U_1 - t_b) * k * I_N$
Minimum operating voltage activation	104-248 [V]	Dynamic grid support via fast feed-in of residual current is activated in the case of voltage events with at least one phase-phase or phase-neutral conductor voltage outside the configured normal operating voltage range. Dynamic grid support via fast feed-in of residual current is deactivated when the voltage returns to the normal operating voltage range.
Maximum operating voltage activation	104-288 [V]	
Reactive current limitation	0-100 [% I _{max}]	The reactive power component of the fast feed-in of residual current is limited to permit a defined proportion of the active current component.

Display	Setting	Description
Minimum support time	1,000-15,000 [ms]	If activated due to a voltage jump in accordance with formula (1) and the configured dead band, the dynamic grid support via fast feed-in of residual current is deactivated after the minimum support time elapses.
Deactivation delay	0 [ms] / 0-500 [ms] IL_LV / UD / 500 [ms] IL-MV	Deactivates dynamic current support after the desired delay as soon as the voltage enters the normal operating range again. This parameter is only available for the country-specific settings IL_LV, IL-MV, and UD.

Other grid-supporting functions in the case of effective power

Permanent power gradients

The maximum effective and apparent power to be installed for a generation system is agreed between the utility and system operator. The device capacity of a system can be set to the exact agreed value using the S_{lim} and P_{lim} settings. To ensure that the load on the devices in a system is uniform, we recommend distributing the power reduction evenly across all devices.

Some grid connection rules require that the agreed reactive power be supplied from every operating point of the system without a reduction in the actual effective power. Given that the inverter has the full P-Q operating range, a reduction in the effective power is, however, required during operation at maximum effective power because an apparent power reserve is not available.

By adjusting P_{lim} , the maximum effective power can be limited in order to establish an apparent power reserve and ensure that the agreed reactive power can be delivered from every effective power operating point.

The diagram below shows the appropriate P-Q operating range with a required example effective power of 48% of the maximum apparent power of the system or 43% of the maximum effective power of the system.

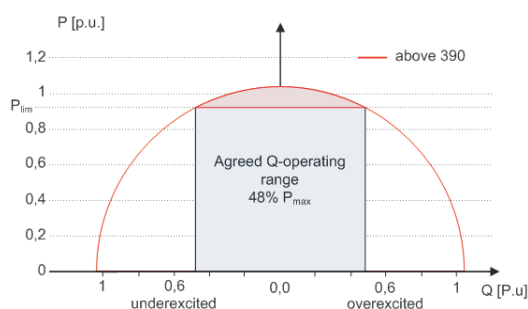

P-Q operating range with limited effective power for PV inverters

The power limitation parameters can be adjusted using SunSpec model DID123. During this process, you should also check whether the internal and/or external power limitation is active.

Internal power limitation	Parameters for external power limitation	Parameters for power limitation
Status = active	Status = active	Parameters in SunSpec Model 123:
Maximum apparent power $S_{lim} = 100,000 \text{ VA}$		"WMaxLimPct" = 50% P_{lim} (approx. 40,000 W)
Maximum active power $P_{lim} = 80\%$ (approx. 80,000 W)	AC fallback active power $P_{fb} = 75\% P_{lim}$ (approx. 60,000 W)	"WMaxLimPct_RvrtTms" = 60 s "WMaxLimPct_RmpTms" = 2 s "WMaxLim_Ena" = 1
	PT1 settling time = 1 s	

If the ramp time "WMaxLimPct_RvrtTms" in the SunSpec model is specified as 0 s, the internal output gradient is used. Otherwise, the set value will be used. Irrespective of the communication protocol used, the settling time "WMaxLim_Ena" is used to transfer the new power value. Otherwise, the internally configured value is used. The additional ramp time "WMaxLimPct_RmpTms" specifies the jump time from one power value to the new power value.

The following formulas are used to calculate the gradient $S_{lim/min}$:

$$\text{GradientWattPerMin} = \frac{\left(\frac{WMaxLimPct}{100} \times P_{lim} - P_{actual}\right)}{WMaxLimPct_{RmpTms}} \times 60 \times \frac{100}{Slim}$$

$$\text{GradientWattPerMin} = \frac{\left(\frac{50\%}{100} \times 80000 \text{ W} - 60000 \text{ W}\right)}{2 \text{ s}} \times 60 \times \frac{100}{100000 \text{ VA}}$$

$$\text{GradientWattPerMin} = -600 \% \text{ Slim} / \text{min}$$

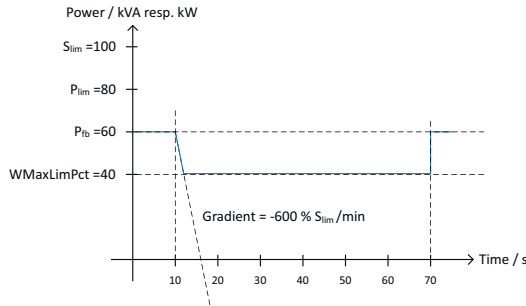

Power gradient according to sample parameters and calculation

The following formulas are used to calculate the Q filter parameter and $\cos \varphi$ gradient:

$$\text{GradientVArPerMin} = \frac{\left(\frac{VArMaxPct}{100} \times Slim - Q_{actual}\right)}{VArPct_{RmpTms}} \times 60 \times \frac{100}{Slim}$$

Formula for calculating the Q filter parameter

$$\text{GradientVArPerMin} = \frac{\left(\frac{VArMaxPct}{100} \times Slim - Q_{actual}\right)}{OutPFSet_{RmpTms}} \times 60 \times \frac{100}{Slim}$$

Formula for calculating the $\cos \varphi$ gradient (internal power gradient)

Parameters for permanent power limitation

Display	Setting	Description
Power limitation	Check activation	Activate or deactivate the power limitation.
Maximum apparent power (S_{lim})	1,000- S_{max} [VA]	The apparent power is limited globally to the configured value in VA. Once S_{lim} has been configured, all of the active and reactive power control values will use S_{lim} as 100% instead of S_{max} .
Maximum active power (P_{lim})	1-100 [% S_{lim}]	The effective power is limited globally to the configured value in % S_{lim} .

Soft start up / power ramp-up limiting

A soft start up function is available to prevent the grid from being negatively impacted by a sudden increase in feed-in power from the inverters. When the inverter is activated or switched on, the increase in power is limited by the set gradient.

It is possible to configure:

- Whether the soft start-up should occur every time the device is switched on
- Whether the soft start-up should occur only upon initial start-up each day
- Whether the soft start-up should occur only when starting up after the device has been switched off by the grid protection

Primarily because there is a risk that many systems could increase their power levels simultaneously after they have been switched off by the grid protection, a soft start-up is usually only required for start-up after a device has been switched off by the grid protection.

The soft start up is implemented by an absolute power limitation that increases with a continuous gradient up to the maximum power. The actual power of the inverter may vary freely below this limit due to a possible fluctuation in the available power or the set value, but at no time increases above the absolute power limit.

**Power gradient
normal operation**

In the case of very large systems, it may be necessary to limit the maximum change in power during normal operation. The grid power feed-in is increased or decreased according to the configured gradients when the specified set value (for increasing and decreasing power) is changed and when the solar irradiation (for increasing power) is changed. The change in power cannot be limited if solar irradiation is reduced.

The function is not active if there are changes in power that are defined by a different grid support function, such as power recovery after fault ride through, $P(f)$, $P(U)$.

Enhanced island detection

Enhanced island detection

Due to decentralized generation, there is the possibility that a deactivated part of the grid will remain live in an unintended island due to a local balance between load and generation in this part of the grid. The detection of unintended island formation is an important function of decentralized generating units and plays a role in preventing damage to equipment as well as ensuring the safety of personnel.

Depending on the structure and operation of the distribution grid, there are a number of dangers:

- In case of maintenance work in a distribution grid, persons may be endangered if the deactivated part of the grid remains live as an island. This is especially the case if not all safety rules are followed.
- If fast reclosure is used in a distribution grid and the deactivated part of the grid remains live as an island, reclosure will likely occur with a phase shift, which could damage rotating machinery in the grid.
- In the event of a fault in a medium-voltage grid, the faulty part of the grid is disconnected. If the fault has a significant resistance, the deactivated part of a medium-voltage grid remains live as an island. Depending on the type of fault, but explicitly in the case of a fault in the transformer, dangerous medium voltage might be present in exposed areas, even on low-voltage appliances.

In the case of the last example in particular, the generating units need to be disconnected very quickly to cause the forming island to collapse. At the same time, any island formation detection method may cause false tripping. The industry is therefore working continually to develop methods that are fast and reliable and can also be depended on to prevent false tripping.

Enhanced island detection

Enhanced island detection uses a reliable island detection strategy based on the characteristic differences between an interconnected grid and an islanded grid, thus ensuring rapid and reliable detection and prevention of false tripping.

An interconnected grid is dominated by rotating machinery, so the frequency is proportional to the effective power balance and the voltage is proportional to the reactive power balance. By contrast, an islanded grid behaves like an oscillating circuit, so the frequency is proportional to the reactive power balance and the voltage is proportional to the effective power balance. The active enhanced anti-islanding method detects this difference by monitoring the behavior of the grid. The enhanced anti-islanding method monitors the natural fluctuation in the grid frequency and injects a minimal reactive power that is proportional to the rate of change of the frequency. In the moment an island is formed, the connected grid closes a positive feedback loop which allows the inverter to detect the change in the situation and to disconnect. If an island forms, the inverter disconnects within several 100 ms, and well below 1,000 ms.

- The number of inverters connected in parallel does not affect the reliability of this function.
- This method also guarantees that effects on the distribution grid are minimized.
- The function has not been found to have any effects on harmonic content, flicker, and grid stability during normal operation.

This detection method is combined with a two-stage passive rate of change of frequency (ROCOF) observation. If the ROCOF of the grid exceeds the configured shutdown threshold (stage 1) for the configured shutdown time, the

device switches to zero current mode. If the ROCOF of the grid exceeds the configured shutdown threshold (stage 2) for the shutdown disconnection time, the device switches off. In case of an island, this will shut down the island instantaneously. If the grid stabilizes, which might be the case if the ROCOF event was due to a brief disturbance in the grid, the inverter will resume normal operation. If stage 1 is active, the device has switched to zero current mode and will recommence feed-in after a few 100 ms. If stage 2 is active, the device has switched off and the configured reconnection conditions apply.

Q on Demand

Q on Demand



DANGER!

If night shutdown is disabled ("Q on Demand" mode), there may still be a high level of DC voltage on both the string collector and the device, despite the string collector being switched off.

Severe injury and death may result.

- ▶ The device must also be disconnected from the power supply on the AC side when carrying out maintenance.
- ▶ We recommend that a danger notice to this effect be affixed to the string collector.

The "Q on Demand" function can also provide a reactive power Q outside of grid power feed operation to stabilize the grid (e.g., at night).

Important prerequisites:

- The "Night Shutdown" function has been disabled in the menu
- Device is connected on the AC side
- Device has been in grid power feed operation.

The specifications that the inverter receives from the utility through the system controller via Ethernet or RS485 take first priority. The parameters for Q constant and Q(U) stored in the inverter take second priority.

If the AC supply is disconnected during "Q on Demand" operation outside of grid power feed operation, the "Q on Demand" function can only be used again following proper grid power feed operation (if there is an adequate DC supply). The existing "Night Shutdown" that has been deactivated also remains active.

The following figures show normal operation in the P-Q operating range during the day (grid power feed operation) (1) and "Q on Demand" operation at night (2).

Only reactive power is produced at night. A small amount of effective power will inevitably be required for the internal power supply in order to keep the pre-configured reactive power functions in "Q on Demand" mode (see item 2 in the negative P range).

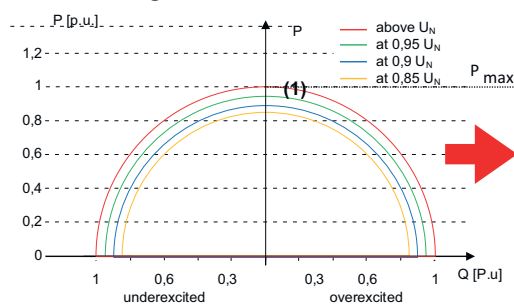

(1) Normal operation: Effective power and reactive power supply at different voltages.

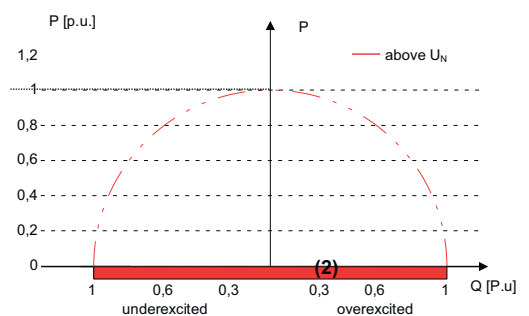

(2) "Q on Demand" operation: Reactive power supply with nominal grid voltage outside grid power feed operation.

Appendix

Care and maintenance

Safety



DANGER!

Lethal voltages are still present in the connections and leads of the device even after the device has been switched off and disconnected.

Touching the leads or terminals/busbars in the device can result in severe injuries or death.

- ▶ The device must be permanently installed prior to electrical connection.
- ▶ Comply with all safety rules and current technical connection specifications of the responsible utility.
- ▶ The device must only be opened and serviced by a qualified electrician.
- ▶ Switch off the mains voltage by switching off the external circuit breakers.
- ▶ Check that all AC and DC cables are completely free of current using a clamp ammeter.
- ▶ Do not touch the leads or terminals/busbars when switching the device on and off.
- ▶ Keep the device closed when in operation.



DANGER!

Dangerous voltage due to two operating voltages

Touching the leads or terminals/busbars in the device can result in severe injuries or death. The discharge time of the capacitors is up to 5 minutes.

- ▶ The device must only be opened and serviced by a qualified electrician who has been authorized by the utility.
- ▶ Observe the information provided on the warning sticker of the device housing.
- ▶ Before opening the device: Disconnect the AC and DC sides and wait at least 5 minutes.



WARNING!

If the device is not completely disconnected from the voltage source, the fan may start unexpectedly.

The fan can sever or injure limbs.

- ▶ Before working on the device, make sure that the device is disconnected from all voltage sources.
- ▶ After disconnecting from all voltage sources, wait for at least another 5 minutes before starting maintenance work.



CAUTION!

Cleaning with compressed air or other unsuitable means can result in damage.

This can cause damage to the device.

- ▶ Do not use compressed air or high-pressure cleaners.
- ▶ Use a vacuum cleaner or a soft brush to remove dust from the fan covers and from the top of the device on a regular basis.
- ▶ Remove soiling from ventilation inlets if necessary.

General

The inverter is designed so that it does not require additional maintenance work. Nevertheless, a few points must be considered during operation to ensure that the inverter works perfectly.

Maintenance

Maintenance and service work may only be carried out by Fronius-trained service technicians.

Cleaning

Wipe the inverter, if necessary, with a damp cloth.
Do not use cleaning agents, scouring agents, solvents, or similar products to clean the inverter.

Cleaning the fan drawer

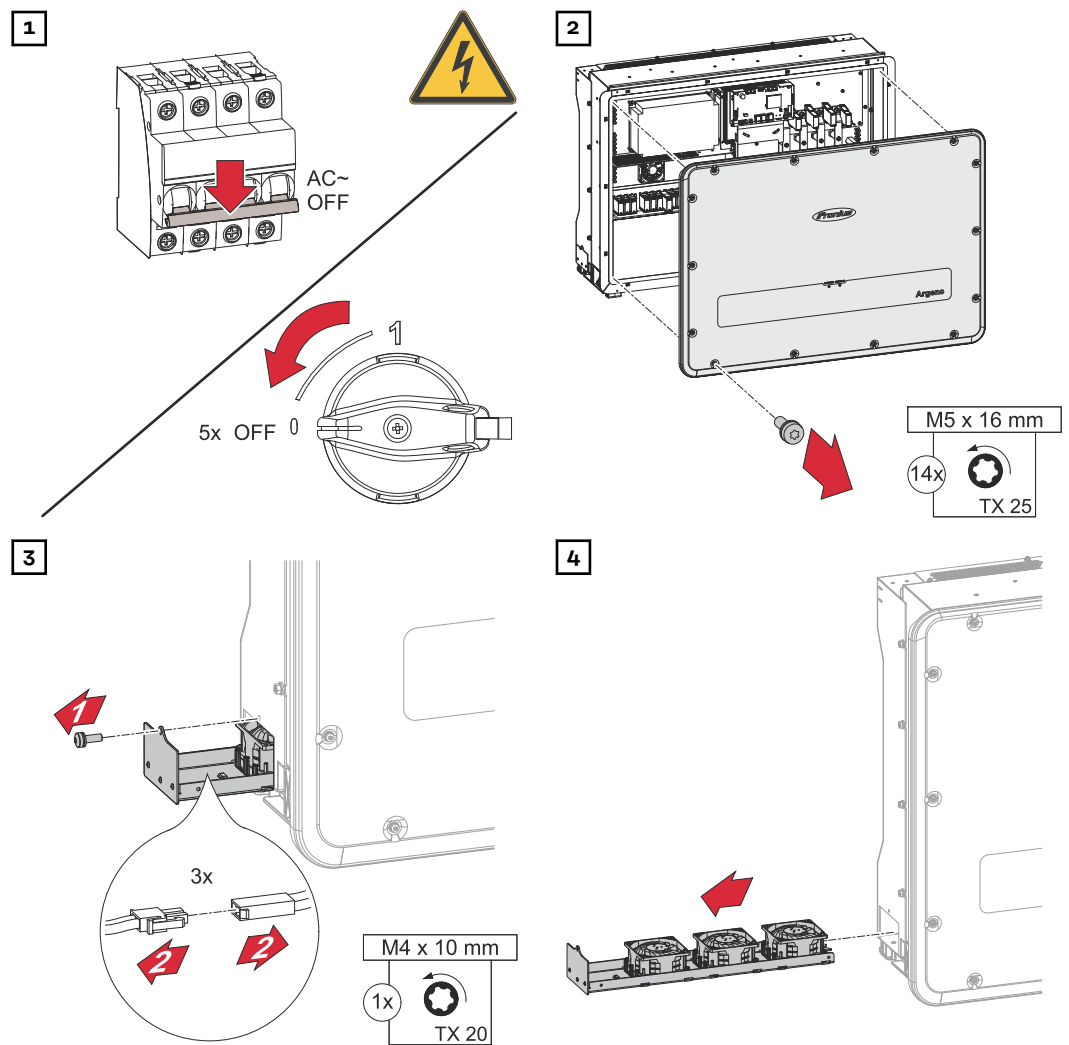

5 Use a suitable brush to remove dirt and dust particles from all fans.

6 Remove any dust inside by tapping gently on the side of the fan grille.

7

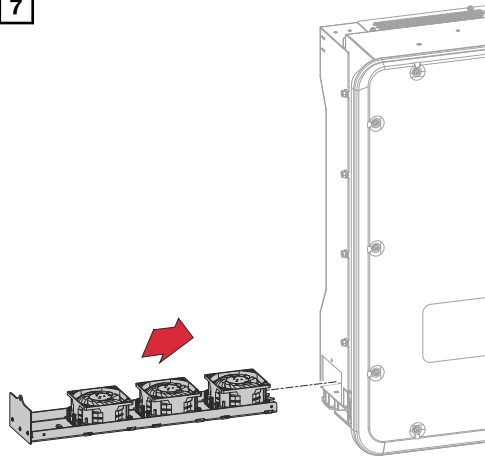

8

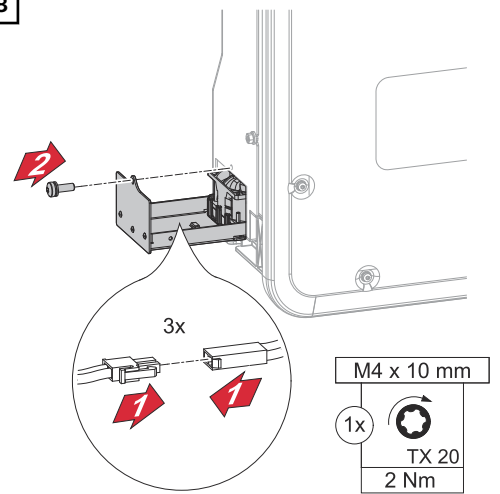

9

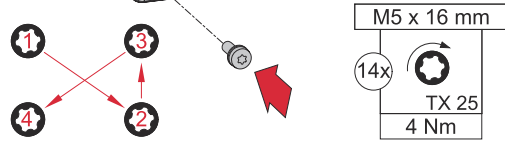
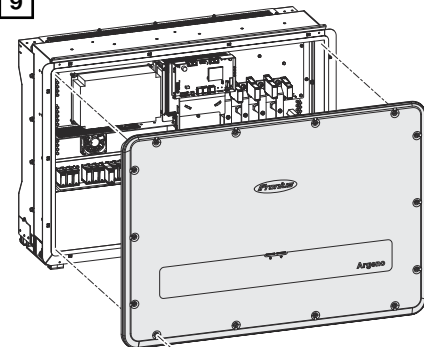

10

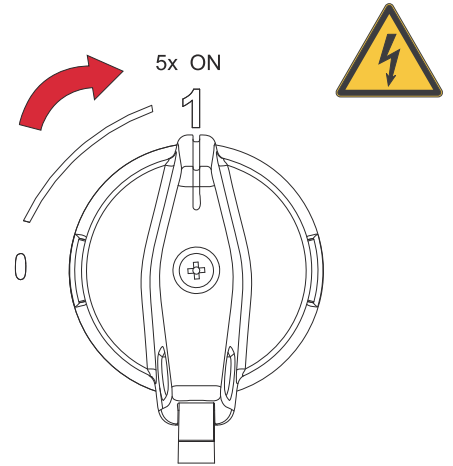

11

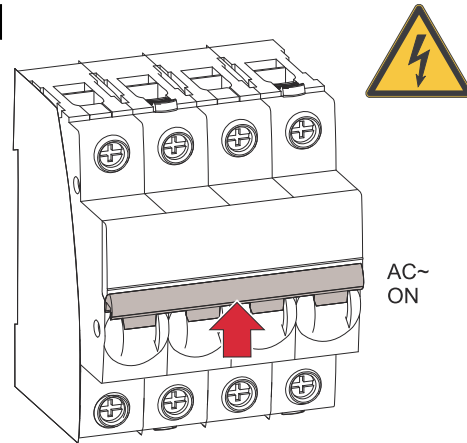

Status codes and remedy

Status codes

LEDs do not light up

Cause: No mains voltage

Remedy: Contact a Fronius-trained service technician

The device stops grid power feed operation shortly after switching on even though there is irradiation present

Cause: Defective section switches in the device

Remedy: If the section switches are defective, the device will recognize this fault during the self-test.

Remedy: Contact a Fronius-trained service technician

Device is active but not connected to the grid. The operating LED indicates a grid fault.

Cause: Due to a grid fault (over/undervoltage, over/underfrequency), the device stops the feed-in process and disconnects from the grid for safety reasons.

Remedy: Contact a Fronius-trained service technician

The mains fuse trips.

Cause: The inverter exceeds its nominal current for a short time in case of a high level of irradiation. The mains fuse capacity is too low.

Remedy: Contact a Fronius-trained service technician

Cause: If the mains fuse trips immediately when the device goes into grid power feed operation, the device's hardware is likely damaged.

Remedy: Contact a Fronius-trained service technician

The device displays an impossible daily peak value

Cause: Faults in the grid

Remedy: The device continues to operate as normal without losses in the yield, despite displaying an incorrect daily peak value. The value is reset overnight.

Remedy: To reset the value immediately, see [De-energizing the inverter and switching it back on](#)

Daily yields do not match the yields on the electricity meter

Cause: The measuring elements in the device have been selected to ensure maximum yields. Due to tolerances, the daily yields displayed may deviate from the values on the electricity meter by up to 15%.

Remedy: No action necessary.

Device is active but not connected to the grid

Cause: The PV module voltage or power is not sufficient for feed-in (solar irradiation is too low). The inverter checks the grid parameters before the feed-in process begins. The length of time it takes to switch on differs from country to country depending on the applicable standards and regulations and can last several minutes. The start-up input voltage setting may be incorrect.

Remedy: No action necessary.

Remedy: If status code persists, contact a Fronius-trained service technician.

In spite of high irradiation levels, the inverter does not feed the maximum power into the grid.

Cause: The device reduces the power because the temperatures inside the device are too high.

Remedy: Ensure sufficient cooling of the device.

Remedy: Remove any foreign matter from the device

Remedy: If the first two steps do not help, contact a Fronius-trained service technician

Cause: A module string is disconnected from the device due to a defective DC fuse.

Remedy: Contact a Fronius-trained service technician

Technical data

Argeno 125

Input data	
Max. input voltage (at 1,000 W/m ² /-10 °C in an open circuit)	1,100 V _{DC}
Nominal input voltage	620 V _{DC}
DC starting voltage	250 V _{DC}
MPP voltage range	550-850 V _{DC}
Number MPP-controller	10
Maximum input current (I _{DC max}) PV1-PV10 per string	30 A 20 A
Max. short circuit current ⁸⁾ PV1-PV10 per string	37.5 A 25 A
Max. power / MPP tracker	15.5 kW
Max. array power (P _{PV max}) in total	250 kWp
DC overvoltage category	2
Max. inverter backfeed current to the array ³⁾	0 A ⁴⁾

Output data	
Grid voltage range during permanent operation (phase/phase)	305-560 V _{AC}
Max. grid voltage range (up to 100 s)	612 V _{AC}
Rated grid voltage	380/400 V _{AC} (3P+(N)+PE) ¹⁾
France (4,210,472 / 4,210,472A)	400 V _{AC} (3P+N+PE) ¹⁾
Rated power (at 400 VAC)	125 kVA
Rated apparent power	125 kVA
Rated frequency	50/60 Hz ¹⁾
Maximum output current/phase	182 A
Initial symmetrical short-circuit current/phase I _K "	190.2 A
Power factor (cos phi)	0.8 ind ... 0.8 cap. ²⁾
Grid connection	3~ (N)PE 380 / 220 V _{AC} 3~ (N)PE 400 / 230 V _{AC}
Earthing systems	TN-C (not with 4,210,472) / TN-C-S / TN-S / TT, solid grounded wye
Maximum output power	125 kW
Nominal output power	125 kW
Rated output current / phase	3x 180.4 A
Total harmonic distortion	< 3%

Output data	
AC overvoltage category	3
Current (inrush) ⁵⁾	< 20 A [RMS (20 ms)] ⁴⁾
Duration of short circuit alternating current (max. output fault current)	3 x 182.66 A

General data	
Night-time power loss = standby consumption	4.8 W 400 V AC no LAN
European efficiency	98.7%
Maximum efficiency	99.1%
Safety class	1
EMC emission class	A ¹⁰⁾
Pollution degree inside housing	2
Outside housing	3
Permitted ambient temperature	- 25 °C-+60 °C
Permitted storage temperature	- 40 °C-+80 °C
Relative humidity	0-100%
Noise emission	< 60 dB(A) (ref. 20 µPA)
Protection class	IP 66
Dimensions (height x width x depth)	740 x 1,023 x 330 mm
Weight	85 kg
Inverter topology	Non-insulated, no transformer

Protection devices	
DC disconnector	Integrated
Cooling principle	Controlled forced-air ventilation
RCMU	Integrated
DC isolation measurement	integrated ²⁾
Overload performance	Operating point shift Power limitation
Active anti-islanding method	Phase shift process, cyclical phase jump
AFCI	Integrated
AFPE (AFCI) classification (according to IEC63027)	F-I-AFPE-2-4-5

Explanation of footnotes

- 1) The values provided are standard values. If required, the inverter is customized for a specific country.
- 2) Depending on the country setup or device-specific settings (ind. = inductive; cap. = capacitive)
- 3) Maximum current from a defective PV module to all other PV modules. From the inverter itself to the PV side of the inverter, this is 0 A.
- 4) Assured by the electrical design of the inverter
- 5) Peak current when turning on the inverter
- 6) The values provided are standard values. These values must be adjusted according to requirements and PV output.
- 7) The value provided is a max. value. If this value is exceeded, this may impair the function.
- 8) $I_{SC\ PV} = I_{CP\ PV} \geq I_{SC\ max} = I_{SC\ (STC)} \times 1.25$ acc. to e.g.,: IEC 60364-7-712
- 9) Software class B (single-channel with periodic self-test) according to IEC 60730-1 Appendix H.
- 10) Standards:
 - Interference immunity
 - EN IEC 61000-6-1:2019
 - EN 61000-6-1:2007
 - EN IEC 61000-6-2:2019
 - EN 61000-6-2:2005/AC:2005
 - EN 62920:2017/A11:2020 Class A
 - Emitted interference
 - EN 62920:2017/A11:2020 Class A*
 - EN 55011:2016/A11:2020+ A2:2021 Group 1, Class A*
 - EN IEC 61000-6-4:2019
 - EN 61000-6-4:2007 +A1:2011
 - Grid interferences
 - EN 61000-3-11:2000
 - EN IEC 61000-3-11:2019
 - EN 61000-3-12:2011

Relevant Standards and Directives

CE Conformity Marking

The equipment complies with all the requisite and relevant standards and directives that form part of the relevant EU directive, and therefore is permitted to display the CE mark.

Mains failure

The standard measurement and safety procedures integrated into the inverter ensure that the power feed is immediately interrupted in the event of a grid failure (for example shut-off by the grid operator or damage to lines).

Service, warranty terms and conditions, and disposal

Fronius SOS

Under sos.fronius.com you can retrieve warranty and device information at any time, start troubleshooting independently, and request replacement components.

For more information on spare parts, contact your installer or point of contact for the PV system.

Fronius manufacturer's warranty

Detailed, country-specific warranty conditions are available at www.fronius.com/solar/warranty.

To obtain the full warranty period for your newly installed Fronius product, please register at www.solarweb.com.

Disposal

The manufacturer, Fronius International GmbH, will take back the old device and arrange for it to be professionally recycled. Observe the national regulations for the disposal of electronic equipment.

Circuit diagrams and dimensions

Dimensions of the mounting bracket

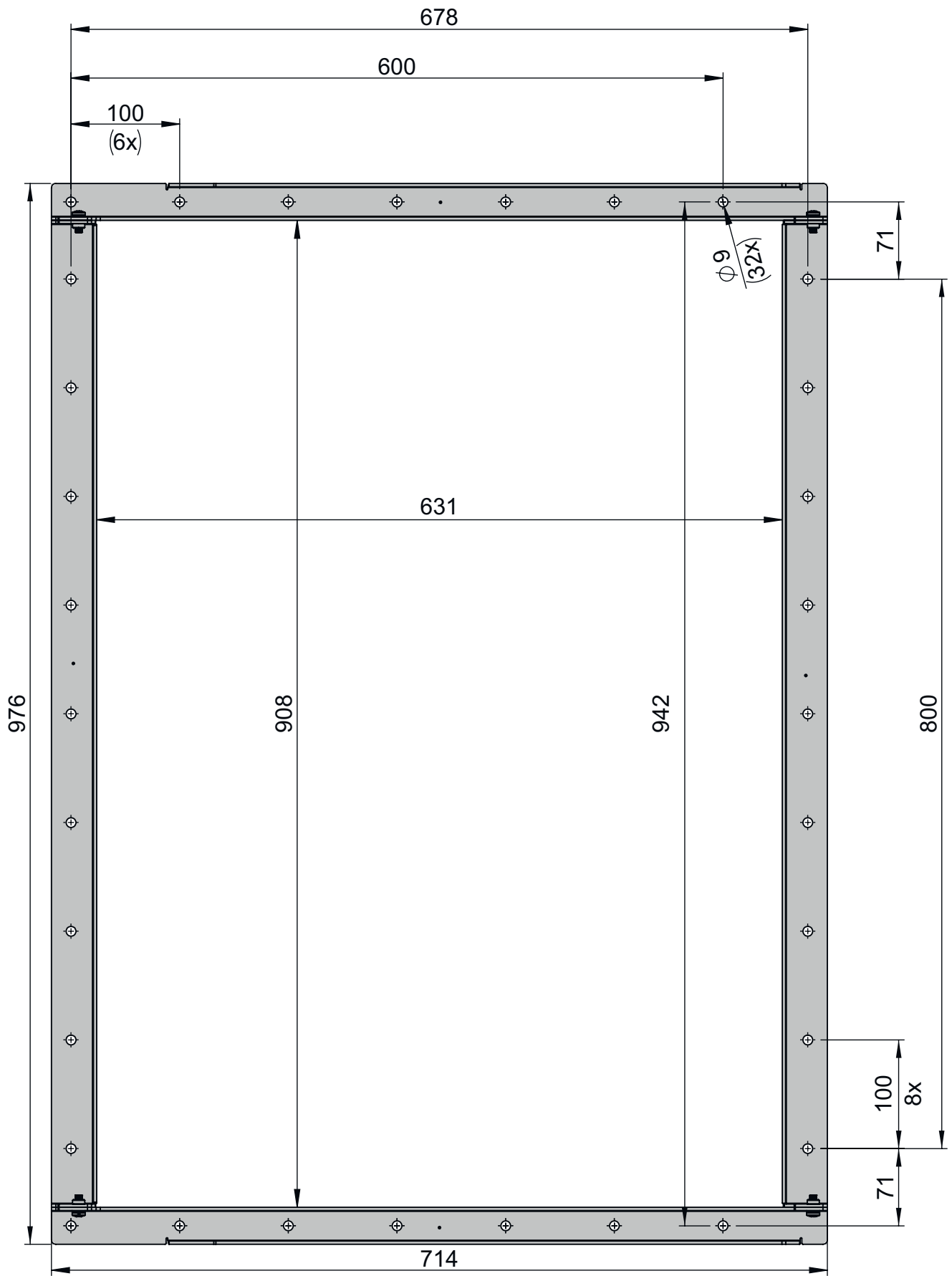



fronius.com/en/solar-energy/installers-partners/products-solutions/monitoring-digital-tools

**MONITORING &
DIGITAL TOOLS**

Fronius International GmbH

Froniusstraße 1
4643 Pettenbach
Austria
contact@fronius.com
www.fronius.com

At www.fronius.com/contact you will find the contact details of all Fronius subsidiaries and Sales & Service Partners.